



Agenda
Lodging Tax Advisory Committee Meeting
Monday, October 14, 2024
Richland City Hall ~ Council Chambers
625 Swift Boulevard

Committee Members: Cruz, Garza, Sako and Stephens

Council Liaison: Councilmember Lukson

Regular Meeting - 5:30 p.m.

Call to Order/Attendance:

Public Comments: Please limit public comments to 2 minutes.

Approval of Minutes: (Approved by Motion)

1. Approval of the February 13, 2024 Lodging Tax Advisory Committee Meeting Minutes
 - Hollie Alexander, Communications & Marketing Manager

Budget Overview:

2. 2025 Lodging Tax Funding Overview
 - Brandon Allen, Finance Director

2024 Grant Funded Projects - Summary to Date:

3. 2024 Activities and Projects Update
 - Gail Everett, Communications & Marketing Specialist

Hotel/Motel Grant Applications:

4. Yes & Productions - 2025 Summer Musical
 - Jill Madison
5. Tri Town Get Down - Fusion Fest Music & Arts Festival
 - Emerald Spark
6. City of Richland - Columbia Playfields' North Parking Lot Restoration
 - Christopher Waite, Parks & Public Facilities Director
7. City of Richland - Columbia Point Marina Park Dock and Marina Revitalization
 - Christopher Waite, Parks & Public Facilities Director
8. City of Richland - Kiosk Renew and Replace
 - Christopher Waite, Parks & Public Facilities Director
9. City of Richland - Side by Side
 - Christopher Waite, Parks & Public Facilities Director

10. Richland Chamber of Commerce - Cool Desert Nights
 - Nicholas Tabor
11. Visit Tri-Cities - IRONMAN 70.3 Washington Tri-Cities
 - Kevin Lewis
12. Three Rivers Ultimate - Hanford Howl 2025
 - Trevor Kilgannon
13. Three Rivers Ultimate - 2025 Heat Up Ultimate Frisbee Tournament
 - Trevor Kilgannon
14. Babe Ruth - Baseball Infield Renovation
 - Patrick Barrett
15. Mid-Columbia BMX - Starting Hill Improvement Phase I - Gate Replacement
 - Sam McPeek
16. Tri-City Water Follies - Columbia Cup and Over the River Air Show
 - Mark Williams
17. Friends of Badger Mountain - Little Badger Mountain Loop Trail Master Plan Implementation
 - David Comstock
18. FORMEC - Apple Cup, ZMax Cars Tour, ARCA Series West, and Fall Classic
 - Laci Tolar
19. Allied Arts Association - Art in the Park Festival
 - Brandie Soden
20. Northwest Power Boat Association - Richland Regatta
 - Charlie Grigg
21. Stephens Media Group - Live@5
 - Jennifer Little
22. Three Rivers Folklife Society - Tumbleweed Music Festival
 - Katrina Knight
23. Tri-Cities Sunrise Rotary - See3Slam 2025 - 3 on 3 Basketball Tournament
 - Terry Marie Fleischman

Presentations:

New Business:

24. Grant Funding Recommendation to Council
 - Hollie Alexander, Communications & Marketing Manager

Adjournment

Richland City Hall is ADA-accessible. Any individual who has difficulty attending the meeting in-person may request to provide comments remotely. (RCW Chapter 42.30) Requests for sign interpreters, audio equipment, and/or other special services must be received 48 hours before the meeting by calling the City Clerk's Office at 509-942-7389.



LODGING TAX ADVISORY COMMITTEE AGENDA ITEM ITEM COVERSHEET

Meeting Date: 10/14/2024

Agenda Category: Approval of Minutes

Prepared By: Hollie Alexander, Communications & Marketing Manager

Subject:

Approval of the February 13, 2024 Lodging Tax Advisory Committee Meeting Minutes

Department:

City Manager

Recommended Motion:

Summary:

Draft minutes from the February 13, 2024 Lodging Tax Advisory Committee meeting are presented for the Committee's review and approval.

Fiscal Impact:

None.

Attachments:

- I. Draft February 13, 2024 LTAC Meeting Minutes



MINUTES

Lodging Tax Advisory Committee Meeting
Tuesday, February 13, 2024, 5:30 p.m.
Richland Council Chamber Conference Room
625 Swift Boulevard

Lodging Tax Advisory Committee Meeting – 5:30 p.m.

Call to Order

Councilmember Lukson called the meeting to order at 5:38 p.m.

Attendance: Councilmember Lukson	Present
Douglas “Gus” Sako	Present
Hector Cruz	Present
Char Garza	Present
Lacey Stephens	Present

Gail Everett, Communications and Marketing Specialist, was also present.

Public Comments: None

Approval of Minutes: (Approved by Motion)

1. Approval of October 26, 2023 Lodging Tax Advisory Committee Meeting Minutes

MR. CRUZ MOVED AND MR. SAKO SECONDED THE MOTION TO APPROVE THE OCTOBER 26, 2023 LODGING TAX ADVISORY COMMITTEE MEETING MINUTES. THE MOTION CARRIED 4-0. COUNCILMEMBER LUKSON ABSTAINED.

Event and Project Summary to Date

2. Communications and Marketing Specialist, Everett provided a summary of the completed and extended grants from 2023.

Budget Overview

3. 2024 Lodging Tax Funding Overview

Communications and Marketing Specialist Everett reviewed the financial report of estimated funds available after considering current commitments for 2024.

Hotel Motel Grant Applications to Review

4. Mid-Columbia Children's Museum – Feasibility Study

THE \$30,000 FUNDING REQUEST SUBMITTED BY MID-COLUMBIA CHILDREN'S MUSEUM FEASIBILITY STUDY DID NOT MEET ELIGIBILITY REQUIREMENTS TO RECEIVE LODGING TAX GRANT PROGRAM FUNDS.

5. Stephens Media Group – Live@5

MR. SAKO MOVED AND MS. STEPHENS SECONDED THE MOTION TO APPROVE STEPHENS MEDIA GROUP'S FUNDING REQUEST FOR \$5,000. MOTION CARRIED 5-0.

6. Tri-Town Get Down – Tri-Town Get Down Festival

MR. SAKO MOVED AND MS. GARZA SECONDED THE MOTION TO APPROVE TRI-TOWN GET DOWN'S FUNDING REQUEST FOR \$15,000. THE MOTION CARRIED 5-0.

7. Tri-Cities Water Follies/Columbia Cup – Water Follies

MR. SAKO MOVED AND MS. STEPHENS SECONDED THE MOTION TO APPROVE TRI-CITY WATER FOLLIES' FUNDING REQUEST FOR \$15,000. THE MOTION CARRIED 4-0. MS. CRUZ ABSTAINED.

Second 2% - Projects

8. City of Richland – Increase Electrical Capacity at John Dam Plaza

MR. SAKO MOVED AND MR. CRUZ SECONDED THE MOTION TO APPROVE THE CITY OF RICHLAND'S FUNDING REQUEST FOR \$20,000. THE MOTION CARRIED 5-0.

New Business

9. Grant Funding Recommendation to Council

10. Special Project Funding Request

Communications and Marketing Specialist Everett discussed a new budget category called, *Special Project Fund* that appears to open the door to either mid-year applications or grants that don't fit either category but still could benefit tourism. She will gather more information and present it at a future LTAC meeting.

Councilmember Lukson adjourned the meeting at 6:20 p.m.

Approved: _____
Council Liaison Lukson

ATTEST: _____
Gail Everett, Communications & Marketing Specialist

Date Approved:

Date Published:

Draft



LODGING TAX ADVISORY COMMITTEE AGENDA ITEM ITEM COVERSHEET

Meeting Date: 10/14/2024

Agenda Category: Budget Overview

Prepared By: Brandon Allen, Finance Director

Subject:
2025 Lodging Tax Funding Overview

Department:
City Manager

Recommended Motion:

Summary:

Each year, Richland receives funds from the room tax imposed upon hotels & motels located within the City. These funds can be retained by the City or can be expended for a narrow range of projects & activities established by State law. To be considered for funding, proposals must meet criteria as established in RCW 67.28.1815 and prohibits the use of tax receipts for any other purposes. Tourism promotion is defined in RCW 67.28.080 as "activities & expenditures designed to increase tourism, including but not limited to advertising, publicizing, or otherwise distributing information for the purpose of attracting and welcoming tourists; developing strategies to expand tourism; operating tourism promotion agencies; and funding marketing of special events & festivals designed to attract tourists." After review by the LTAC, each applicant will be approved at the full amount or with an adjusted amount or denied. These recommendations will be brought forward to the City Council for final approval.

Fiscal Impact:

Attachments:

- I. Worksheet 2025 Requested Amounts

2025 HOTEL/MOTEL FUNDING REQUESTS

First 2% Available Funds as of 10/9/2024 = \$746,157

ORGANIZATION	PROPOSED USE OF MONEY	2024 ALLOCATION	2025 REQUEST
Allied Arts Association	Art in the Park	\$12,000.00	\$12,000.00
Columbia Basin BMX	National Event Proposal	\$7,000.00	
Northwest Powerboat Association	Richland Regatta	\$16,500.00	\$17,500.00
Red Mountain Event Center - TC Raceways	Four, Multi-Day Racing Events	\$30,000.00	\$40,000.00
Richland Chamber of Commerce	Cool Desert Nights	\$20,000.00	\$25,000.00
Stephens Media Group	Live@5	\$5,000.00	\$5,000.00
Three Rivers Folklife Society	Tumbleweed Music Festival	\$6,000.00	\$7,000.00
Three Rivers Ultimate Frisbee	Hanford Howl Tournament	\$8,000.00	\$10,000.00
Three Rivers Ultimate Frisbee	Heat Up Tournament	\$0.00	\$1,500.00
Tri-Cities Sunrise Rotary	SEE3SLAM, 3 on 3 Basketball Tournament	\$15,000.00	\$10,000.00
Tri-Cities Water Follies	Columbia Cup & Air Show	\$15,000.00	\$10,000.00
TriTown Get Down / Fusion Fest	Tri-Town / Fusion Music & Art Festival	\$15,000.00	\$15,000.00
Visit Tri-Cities	Ironman Media Production and Marketing	\$25,000.00	\$30,000.00
Yes & Productions Foundation	Summer Musical	\$0.00	\$7,000.00
	Total Requested Balance	\$174,500.00	<u>\$190,000.00</u>

Second 2% Available Funds as of 10/9/24 = \$1,274,922

ORGANIZATION	PROPOSED USE OF MONEY	2024 ALLOCATION	2025 REQUEST
City of Richland - Parks and Public Facilities	Columbia Playfields' North Parking Lot Restoration	\$0.00	\$49,000.00
City of Richland - Parks and Public Facilities	Side-by-side vehicle for event logitstic needs	\$0.00	\$450,000.00
City of Richland - Parks and Public Facilities	Kiosk Upgrade and Replacements	\$0.00	\$100,000.00
City of Richland - Parks and Public Facilities	Columbia Point Marina Park Dock & Marina Upgrade	\$0.00	\$400,000.00
Columbia Basin BMX	Starting Gate Replacement	\$0.00	\$85,250.00
Friends of Badger Mountain	Little Badger Parking Lot and Interpretive Loop	\$0.00	\$326,520.00
Richland Babe Ruth Baseball Fields	Rebuild Bullpens & Install Batting Cages	\$0.00	\$384,000.00
	Total Requested Balance	\$0.00	<u>\$1,794,770.00</u>



LODGING TAX ADVISORY COMMITTEE AGENDA ITEM ITEM COVERSHEET

Meeting Date: 10/14/2024 Agenda Category: 2024 Grant Funded Projects - Summary to Date

Prepared By: Gail Everett, Communications & Marketing Specialist

Subject:
2024 Activities and Projects Update

Department:
City Manager

Recommended Motion:

Summary:
A summary of completed and open events and projects in 2024.

Fiscal Impact:

Attachments:
I. 2024 Grant Summary for LTAC

2023 HOTEL/MOTEL FUND APPLICATIONS

2024 Grant Cycle Results to Date

ORGANIZATION	PROPOSED USE OF MONEY	COMPLETE
ALLIED ARTS ASSOCIATION	ART IN THE PARK	√
COLUMBIA BASIN BMX	RFP NATIONAL BMX EVENT	Extend to 2025
NORTHWEST POWER BOATS	RICHLAND REGATTA	√
RED MOUNTAIN EVENT CENTER - TC RACEWAYS	RACING EVENTS	
RICHLAND CHAMBER OF COMMERCE	COOL DESERT NIGHTS	√
STEPHENS MEDIA GROUP	Live@5	SEPT EVENT
THE CITY OF RICHLAND	BID REVITALIZATION PROJECTS	Waiting for RPT
THE CITY OF RICHLAND	IRONMAN SUPPORT	SEPT EVENT
THE CITY OF RICHLAND	WINTER WONDERLAND	DEC EVENT
THE RUDE MECHANICALS	SHAKESPEARE IN THE PARK	Waiting for Rpt
THREE RIVERS FOLKLIFE SOCIETY	TUMBLEWEED MUSIC FESTIVAL	Waiting for Rpt
THREE RIVERS ULTMATED FRISBEE	HANDFORD HOWL	OCT EVENT
TRI-CITIES SUNRISE ROTARY CHARITY CLUB	SEE3SLAM	√
TRI-CITY WATER FOLLIES	COLUMBIA CUP	Waiting for Rpt
UNLEASHED ENTERTAINMENT	TRI-TOWN GET DOWN MUSIC FEST	√
VIST TRI-CITIES	IRONMAN MARKETING	SEPT EVENT
PROJECTS - 2ND 2%		
CITY OF RICHLAND	ELECTRICAL UPGRADE AT JOHN DAM PLAZA	
CITY OF RICHLAND DEVELOPMENT SERVICES	BID REVITALIZATION PROJECTS	
COLUMBIA BASIN BMX	DESIGN AND BUILD DIRT TRACK	waiting for invoice
COLUMBIA BASIN BMX	TRACK LIGHTING UPGRADE	waiting for invoice
RED MOUNTAIN EVENT CENTER - TC RACEWAYS	PHASE 1 IMPROVEMENTS	
ORGANIZATION / EXTENDED	GRANTS EXTENDED TO 2024	
BM ICE AGE FLOOD GRANT EXTENDED TO 2024	BADGER MNT ICE AGE FLOODS	
CITY OF RICHLAND DEVELOPMENT SERVICES	BID REVITALIZATION PROJECTS	Waiting for Rpt
ORGANIZATION / CANCELLED	GRANTS CANCELLED	
SPECIAL OLYMPICS	2023 STATE GAMES	CANCELLED



LODGING TAX ADVISORY COMMITTEE AGENDA ITEM ITEM COVERSHEET

Meeting Date: 10/14/2024

Agenda Category: Hotel/Motel Grant Applications

Prepared By: Jill Madison

Subject:

Yes & Productions - 2025 Summer Musical

Department:

City Manager

Recommended Motion:

Summary:

Yes & Productions will put on a summer musical at the City of Richland HAPO Community Stage. The event will include a diverse cast and a live orchestra. Yes & Productions is requesting \$7,000 out of a total budget of \$60,000.

Fiscal Impact:

Yes & Productions is requesting \$7,000.

Attachments:

- I. Yes & Productions - 2025 Summer Musical

Submission # 3482436
 IP Address 71.84.185.85
 Submission Recorded On 09/13/2024 8:45 AM
 Time to Take Survey 20 minutes, 3 seconds

Page 1 - Applicant Information



2025 Lodging Tax Grant Application

Please review the [LTAC Program Information](#) prior to beginning the application process.

Preview the application questions before you begin. The application is a one-time process; you cannot pause, save, or restart once you begin.

APPLICANT INFORMATION

* **1. Name of Organization** ?

Yes And Productions Foundation

* **2. Business or Agency Type**

Non-Profit

* **3. Attach Completed W-9 Form** ?

YesAndProductions Foundation W9.pdf

* **4. Non-Profit Agencies - Attach Proof** ?

0019838172_Certificate.pdf

* **5. Applicant Name** ?

Jill Madison

* **6. Applicant Title or Organizational Role**

Executive Director

* **7. Full Address**

2519 Oak Hill Court
 Richland Washington 99352

* **8. Applicant Phone Number** ?

(206) 612-8820

* **9. Applicant Email Address** ?

jill@yesand.show

Page 2 - Grant Details

GRANT DETAILS

* **10. Dollar Amount of Grant Funding Requested** ?

7,000.00

* **11. Grant Use Type** ?

Event: on City-owned Property or Facility

* **12. For events or projects on City-owned property, please provide the name of the City employee you have reviewed this application with.** ?

Sherry Gartside

* **13. Title of the Proposed Event or Project** ?

Yes And Productions 2025 Summer Musical

* **14. Event or Project Description (will be used in the contract language if granted)** ?

Yes& Productions will put on a vibrant summer musical at the City of Richland HAPO Stage, where 400-600 attendees gather each night to enjoy an outdoor theater spectacle. Featuring a large, diverse cast and a live orchestra, the production brings to life dynamic performances under the stars. With food trucks offering local delights, this event promises to be an unforgettable cultural experience, drawing community members together to celebrate the arts in a scenic outdoor setting.

Non-Grant Funding Sources and Amounts

* **15. Tourism Marketing - Name of Funding Source** ?

Ticket sales and private sponsorship

* **16. Tourism Marketing - Dollar Amount** ?

500.00

* **17. Event/Festival Marketing - Name of Funding Source** ?

Ticket sales and private sponsorship

18. Event/Festival Marketing - Dollar Amount ?

500.00

19. Tourism Facility Operation - Name of Funding Source ?

n/a

20. Tourism Facility Operation - Dollar Amount ?

SKIPPED

* 21. TOTAL NON-GRANT FUNDING BUDGET - Dollar Amount ?

1,000.00

Grant Funding Requested - Planned Amounts and Distribution

22. Event/Festival Marketing - Dollar Amount ?

3,000.00

23. Tourism Marketing - Dollar Amount ?

2,000.00

24. Tourism Facility Operation - Dollar Amount ?

2,000.00

* 25. TOTAL OF GRANT FUNDS - Dollar Amount ?

7,000.00

ATTENDANCE ESTIMATES

The State of Washington **requires** attendance estimates, here are the accepted methods of calculation:

Direct Count: Actual count of visitors using methods such as paid admissions or registrations, clicker counts at entry points, vehicle counts or number of chairs filled. A direct count may also include information collected directly from businesses, such as hotels, restaurants or tour guides, likely to be affected by an event.

Indirect Count: Estimate based on information related to the number of visitors such as raffle tickets sold, redeemed discount certificates, brochures handed out, police requirements for crowd control or visual estimates.

Representative Survey: Information collected directly from individual visitors/participants. A representative survey is a highly structured data collection tool, based on a defined random sample of participants, and the results can be reliably projected to the entire population attending an event and includes margin of error and confidence level.

Informal Survey: Information collected directly from individual visitors or participants in a non-random manner that is not representative of all visitors or participants. Informal survey results cannot be projected to the entire visitor population and provide a limited indicator of attendance because not all participants had an equal chance of being included in the survey.

Structured Estimate: Estimate produced by computing known information related to the event or location. For example, one jurisdiction estimated attendance by dividing the square footage of the event area by the international building code allowance for persons (3 square feet).

* 26. Predicted Overall Attendance - Estimation Method Used ?

Direct Count

* 27. Predicted Overall Attendance - Estimated Number ?

3,000

* 28. Predicted Attendance, 50+ Miles - Estimation Method Used ?

Structured Estimate

* 29. Predicted Attendance, 50+ Miles - Estimated Number ?

500

* 30. Predicted Attendance, Out of State, Out of Country - Estimation Method Used ?

Structured Estimate

* 31. Predicted Attendance, Out of State, Out of Country - Estimated Number ?

250

* 32. Predicted Attendance, Paid for Overnight Lodging - Estimation Method Used ?

Structured Estimate

* 33. Predicted Attendance, Paid for Overnight Lodging - Estimated Number ?

250

* 34. Predicted Attendance, Did Not Pay for Overnight Lodging - Estimation Method Used ?

Structured Estimate

* 35. Predicted Attendance, Did Not Pay for Overnight Lodging - Estimated Number ?

2,500

36. Predicted Paid Lodging Nights - Estimation Method Used ?

Structured Estimate

*** 37. Predicted Paid Lodging Nights - Estimated Number** ?

2

Page 4 - Conditions for Grant Approval

CONDITIONS FOR GRANT APPROVAL

38. Supplemental #1 ?

Yes And Productions City of Richland Tourism Grant Proposal.pdf

39. Supplement #2 ?

****SKIPPED****

I acknowledge and agree to the below grant funding criteria:

1. I may be required to make a presentation to the advisory committee about my event/project.
2. All advertising will include the (provided) City of Richland logo and/or the phrase "Funding provided by City of Richland Lodging Tax Grant program."
3. I agree to submit marketing materials for approval by the Communications & Marketing Manager (or their designee) prior to publishing.
4. A final project report, including reporting requirements meeting state guidelines outlined in the LTAC Program Information document, and all supporting documents will be submitted to the City of Richland within 90 days of completion of the event or project AND must be expended within the calendar year in which they are granted.
5. I understand that grant progress will be monitored for compliance with scope and timeline.
6. If my event or project is on City-owned property, I have discussed this project with City staff and provided their name above.

*** 40. By typing my full name below, I agree to the above grant funding requirements, that I am authorized by my agency to submit this application and that all information provided herein is true and correct.** ?

Jill Madison

City of Richland - 625 Swift Blvd, MS 39 - Richland, WA 99352
www.ci.richland.wa.us/LodgingTax

Proposal for City of Richland Tourism Grant: Large-Scale Musical Production at HAPO Stage

Introduction: In 2024, Yes And Productions Foundation hosted their very first production of *The Music Man* at the City of Richland's HAPO Stage, marking a significant milestone in the local arts scene. With an average attendance of 400 people per performance and a modest \$1,000 marketing budget, the production exceeded expectations, attracting widespread praise from attendees. Despite the limited marketing focus on out-of-town tourism, the event's success highlighted its potential to become a signature event for Richland, drawing audiences from beyond the immediate community and bolstering local economic growth.

Event Growth Potential: With the support of tourism dollars, Yes And Productions Foundation plans to build upon the success of *The Music Man* by enhancing its future summer musical productions. The additional funding would allow for a more robust marketing strategy, specifically targeting surrounding areas such as the Tri-Cities, Yakima, Spokane, and even parts of Oregon and Idaho. By positioning the production as a major summer event, the City of Richland can attract larger, more diverse audiences, making this annual musical a must-see cultural event.

Attendees of *The Music Man* remarked on the high quality of the show, with many sharing how they immediately told friends and family to attend. One local patron said, "I've never seen such a professional and entertaining show in an outdoor setting like this. I'm bringing my whole family next year!" Another audience member added, "Richland needs more events like this! I'd love to see the summer musical become a staple here." The excitement from the local community demonstrates that a larger production with increased promotion will draw even more attendees, both locally and from surrounding regions.

Economic Impact: As a city with growing cultural and recreational opportunities, Richland is well-positioned to use this event as an anchor for tourism-driven economic development. By attracting out-of-town visitors, the summer musical will contribute to increased hotel bookings, restaurant visits, and other local business engagements. Food trucks and local vendors participating at the event will also see a direct benefit, reinforcing the importance of supporting community-centered arts initiatives.

Investing in this production aligns with the City of Richland's goals of boosting tourism and economic vitality. Transforming the summer musical into a signature event will not only enhance Richland's cultural offerings but also stimulate the local economy through tourism-related spending. In particular, lodging, dining, and retail establishments will benefit from an influx of visitors drawn by a high-quality, large-scale performance.

Conclusion: By granting tourism funding to this event, the City of Richland can help turn a successful local production into a regional attraction that bolsters tourism and economic growth. With a proven track record and the backing of an enthusiastic audience, the potential for growth

is undeniable. Together, we can create a summer musical tradition that not only enhances the cultural life of Richland but also serves as a cornerstone for long-term economic development.

The success of *The Music Man* demonstrates the community's desire for more high-quality cultural events, and with this grant, Richland has the opportunity to elevate its place on the regional arts and tourism map.

Plan for Use of Tourism Dollars

The tourism dollars from this grant will be used strategically to maximize the production's visibility and attract a wider audience from neighboring regions. Specifically, the funds will be allocated as follows:

1. Expanded Marketing Budget:

- **Targeted Digital Ads:** \$1,000 will be allocated to run targeted digital ads (Facebook, Instagram, Google) aimed at surrounding cities and regions, including the Tri-Cities, Yakima, Spokane, Walla Walla, and parts of Oregon and Idaho. The ads will focus on the unique experience of an outdoor summer musical, emphasizing the scenic setting of the HAPO Stage and the quality of the production.
- **Collaborations with Tourism Boards and Hotels:** \$1,000 will be used to partner with regional tourism boards, hotels, and local visitor bureaus. Packages will be created that include discounts on lodging or dining with ticket purchases, incentivizing out-of-town guests to make Richland a destination. Additionally, cooperative marketing efforts with these partners will include promotions on their websites, email campaigns, and social media platforms.
- **Print and Radio Advertising:** \$1,000 will be used for print ads in regional newspapers, as well as radio spots on stations that reach the Tri-Cities, Yakima, and Spokane areas. These ads will highlight the event as a fun, family-friendly summer activity with entertainment and local food trucks.
- **Event Posters and Flyers:** \$1,000 will be spent on producing and distributing event posters and flyers in high-traffic areas like visitor centers, hotels, restaurants, and tourist attractions in nearby cities, creating visibility in places where potential attendees frequent.

2. Production Enhancement:

- \$2,000 will be used to enhance the overall production value, making the show an even bigger draw. This includes additional lighting, sound, and set design to create a visually stunning and professional experience that stands out as a premier event in the region.

3. Outreach to Tourism Influencers:

- \$500 will be dedicated to collaborating with local influencers and travel bloggers who focus on the Pacific Northwest. By inviting them to experience and promote the musical, we can organically spread the word to their followers, highlighting Richland as a vibrant cultural destination.

4. Out-of-Town Guest Experience:

- \$500 will be allocated to improving the experience for out-of-town guests, including enhanced amenities like shuttle services from hotels to the venue, seating upgrades, and VIP experiences for those traveling from outside the immediate area. This will create a seamless and elevated experience for tourists, encouraging repeat visits.

Marketing Strategy for Out-of-Town Guests

To draw in a diverse audience from outside Richland, our marketing strategy will focus on promoting the musical as a unique summer destination event that offers both entertainment and an opportunity to explore the area. The following initiatives will be key to attracting out-of-town visitors:

1. **Regional Digital Ad Campaign:** A digital marketing campaign will be launched across social media platforms (Facebook, Instagram) and Google Ads, targeting users within a 150-mile radius of Richland. This will include professionally produced video trailers of the musical, testimonials from past attendees, and visual content showcasing the outdoor theater experience. The ads will target families, tourists looking for weekend getaways, and arts enthusiasts.
2. **Strategic Partnerships:** We will partner with local tourism bureaus, chambers of commerce, and hotel chains in Richland and the surrounding areas. Joint marketing efforts will include promoting travel packages that bundle hotel stays, tickets to the musical, and dining discounts. Richland's tourism partners will feature the event in their promotional materials, and we'll create reciprocal promotions for tourists visiting the area.
3. **Email Campaigns and Event Listings:** The event will be listed on popular regional event calendars and tourism websites like Visit Tri-Cities, Washington State Tourism, and others that cater to travelers. Additionally, we will work with nearby visitor bureaus and arts councils to send email blasts to their subscriber lists, reaching arts patrons and tourists alike.
4. **Promotional Incentives:** To incentivize out-of-town attendees, special promotions will be created, such as early-bird ticket discounts for those booking from outside of the Tri-Cities area. These promotions will be advertised via digital ads and through our regional partnerships.
5. **Influencer and Blogger Outreach:** Engaging local travel bloggers, influencers, and media outlets who cover Pacific Northwest events will help extend our reach beyond traditional advertising. By hosting influencers at the event, we can generate buzz and authentic social media engagement, showcasing Richland's musical as a premier cultural and tourism experience.

By focusing on these marketing efforts, the musical will not only draw a large local audience but will also appeal to visitors from surrounding areas, making it a true summer event that enhances Richland's standing as a cultural and tourism destination.



LODGING TAX ADVISORY COMMITTEE AGENDA ITEM ITEM COVERSHEET

Meeting Date: 10/14/2024

Agenda Category: Hotel/Motel Grant Applications

Prepared By: Emerald Spark

Subject:

Tri Town Get Down - Fusion Fest Music & Arts Festival

Department:

City Manager

Recommended Motion:

Summary:

Fusion Fest Music and Arts Festival is a multi-day event. The festival will feature a lineup of local and regional acts in a wide range of musical genres; from indie and folk to electronic and hip-hop, as well as visual and performing arts by emerging and established artists. Performance stages, vendors, and food and beverage concessions, including a beer garden will be held in John Dam Plaza. Tri Town Get Down has an operating budget of \$160,000 and is requesting \$15,000.

Fiscal Impact:

Tri Town Get Down is requesting \$15,000.

Attachments:

- I. 24-011 Tri Town Get Down Fusion Fest Music & Arts Festival

Submission # 3483375
IP Address 71.93.13.255
Submission Recorded On 09/13/2024 1:50 PM
Time to Take Survey 14 minutes, 9 seconds

Page 1 - Applicant Information



2025 Lodging Tax Grant Application

Please review the [LTAC Program Information](#) prior to beginning the application process.

Preview the application questions before you begin. The application is a one-time process; you cannot pause, save, or restart once you begin.

APPLICANT INFORMATION

- * **1. Name of Organization** ?
Tri Town Get Down LLC / Fusion Fest LLC
- * **2. Business or Agency Type**
For-Profit
- * **3. Attach Completed W-9 Form** ?
Tri-Town Get Down, LLC W-9.pdf
- 4. Non-Profit Agencies - Attach Proof** ?
SKIPPED
- * **5. Applicant Name** ?
Alicia Cullison
- 6. Applicant Title or Organizational Role**
Event Coordinator
- * **7. Full Address**
723 The Parkway
Richland WA 99352
- * **8. Applicant Phone Number** ?
(509) 542-7765
- * **9. Applicant Email Address** ?
alicia@emeraldsparkevents.com

Page 2 - Grant Details

GRANT DETAILS

- * **10. Dollar Amount of Grant Funding Requested** ?
15,000.00
- * **11. Grant Use Type** ?
Event: on City-owned Property or Facility
- 12. For events or projects on City-owned property, please provide the name of the City employee you have reviewed this application with.** ?
Sherry Gartside
- * **13. Title of the Proposed Event or Project** ?
Fusion Fest Music & Arts Festival (formerly Tri Town Get Down)
- * **14. Event or Project Description (will be used in the contract language if granted)** ?
Fusion Fest Music and Arts Festival is a multi-day event celebrating the Mid-Columbia region's rich culture through music, art, and community activities. The festival will feature a diverse lineup of local and regional acts in a wide range of musical genres, from indie and folk to electronic and hip-hop, as well as visual and performing arts by emerging and established artists. Performance stages, vendors, and food & beverage, including beer gardens will be held in John Dam Plaza.

Non-Grant Funding Sources and Amounts

- 15. Tourism Marketing - Name of Funding Source** ?
Sponsors, investors, and ticket sales
- 16. Tourism Marketing - Dollar Amount** ?
5,000.00
- 17. Event/Festival Marketing - Name of Funding Source** ?
Sponsors, investors, and ticket sales

18. Event/Festival Marketing - Dollar Amount ?

50,000.00

19. Tourism Facility Operation - Name of Funding Source ?

Sponsors, investors, and ticket sales

20. Tourism Facility Operation - Dollar Amount ?

20,000.00

*** 21. TOTAL NON-GRANT FUNDING BUDGET - Dollar Amount** ?

160,000.00

Grant Funding Requested - Planned Amounts and Distribution

22. Event/Festival Marketing - Dollar Amount ?

10,000.00

23. Tourism Marketing - Dollar Amount ?

3,000.00

24. Tourism Facility Operation - Dollar Amount ?

2,000.00

*** 25. TOTAL OF GRANT FUNDS - Dollar Amount** ?

15,000.00

Page 3 - Attendance Estimates

ATTENDANCE ESTIMATES

The State of Washington **requires** attendance estimates, here are the accepted methods of calculation:

Direct Count: Actual count of visitors using methods such as paid admissions or registrations, clicker counts at entry points, vehicle counts or number of chairs filled. A direct count may also include information collected directly from businesses, such as hotels, restaurants or tour guides, likely to be affected by an event.

Indirect Count: Estimate based on information related to the number of visitors such as raffle tickets sold, redeemed discount certificates, brochures handed out, police requirements for crowd control or visual estimates.

Representative Survey: Information collected directly from individual visitors/participants. A representative survey is a highly structured data collection tool, based on a defined random sample of participants, and the results can be reliably projected to the entire population attending an event and includes margin of error and confidence level.

Informal Survey: Information collected directly from individual visitors or participants in a non-random manner that is not representative of all visitors or participants. Informal survey results cannot be projected to the entire visitor population and provide a limited indicator of attendance because not all participants had an equal chance of being included in the survey.

Structured Estimate: Estimate produced by computing known information related to the event or location. For example, one jurisdiction estimated attendance by dividing the square footage of the event area by the international building code allowance for persons (3 square feet).

*** 26. Predicted Overall Attendance - Estimation Method Used** ?

Structured Estimate

*** 27. Predicted Overall Attendance - Estimated Number** ?

2,600

*** 28. Predicted Attendance, 50+ Miles - Estimation Method Used** ?

Structured Estimate

*** 29. Predicted Attendance, 50+ Miles - Estimated Number** ?

600

*** 30. Predicted Attendance, Out of State, Out of Country - Estimation Method Used** ?

Structured Estimate

*** 31. Predicted Attendance, Out of State, Out of Country - Estimated Number** ?

200

*** 32. Predicted Attendance, Paid for Overnight Lodging - Estimation Method Used** ?

Structured Estimate

*** 33. Predicted Attendance, Paid for Overnight Lodging - Estimated Number** ?

800

*** 34. Predicted Attendance, Did Not Pay for Overnight Lodging - Estimation Method Used** ?

Structured Estimate

*** 35. Predicted Attendance, Did Not Pay for Overnight Lodging - Estimated Number** ?

1,800

36. Predicted Paid Lodging Nights - Estimation Method Used ?

Structured Estimate

*** 37. Predicted Paid Lodging Nights - Estimated Number** ?

1,600

Page 4 - Conditions for Grant Approval

CONDITIONS FOR GRANT APPROVAL

38. Supplemental #1 ?

SKIPPED

39. Supplement #2 ?

SKIPPED

I acknowledge and agree to the below grant funding criteria:

1. I may be required to make a presentation to the advisory committee about my event/project.
2. All advertising will include the (provided) City of Richland logo and/or the phrase "Funding provided by City of Richland Lodging Tax Grant program."
3. I agree to submit marketing materials for approval by the Communications & Marketing Manager (or their designee) prior to publishing.
4. A final project report, including reporting requirements meeting state guidelines outlined in the LTAC Program Information document, and all supporting documents will be submitted to the City of Richland within 90 days of completion of the event or project AND must be expended within the calendar year in which they are granted.
5. I understand that grant progress will be monitored for compliance with scope and timeline.
6. If my event or project is on City-owned property, I have discussed this project with City staff and provided their name above.

*

40. By typing my full name below, I agree to the above grant funding requirements, that I am authorized by my agency to submit this application and that all information provided herein is true and correct. ?

Alicia Cullison

City of Richland - 625 Swift Blvd, MS 39 - Richland, WA 99352
www.ci.richland.wa.us/LodgingTax



LODGING TAX ADVISORY COMMITTEE AGENDA ITEM ITEM COVERSHEET

Meeting Date: 10/14/2024

Agenda Category: Hotel/Motel Grant Applications

Prepared By: Christopher Waite, Parks & Public Facilities Director

Subject:

City of Richland - Columbia Playfields' North Parking Lot Restoration

Department:

City Manager

Recommended Motion:

Summary:

Columbia Playfields is an important asset in the City of Richland. It is a high-quality softball complex that attracts players from across the region and state. This facility is a hub for numerous multi-day tournaments annually. The City of Richland is requesting \$450,000 to supplement existing funds to resurface the parking lot. The total project cost is \$600,000.

Fiscal Impact:

The City of Richland is requesting \$450,000.

Attachments:

- I. City of Richland - Columbia Playfields' North Parking Lot Restoration

Submission # 3497544
IP Address 174.231.131.3
Submission Recorded On 09/17/2024 2:49 PM
Time to Take Survey 2 days, 8 minutes, 51 seconds



Please review the [LTAC Program Information](#) prior to beginning the application process.

Preview the application questions before you begin. The application is a one-time process; you cannot pause, save, or restart once you begin.

APPLICANT INFORMATION

*** 1. Name of Organization ?**

City of Richland

*** 2. Business or Agency Type**

Public Agency

*** 3. Attach Completed W-9 Form ?**

COR 2024 W-9.pdf

4. Non-Profit Agencies - Attach Proof ?

SKIPPED

*** 5. Applicant Name ?**

Director Chris Waite

6. Applicant Title or Organizational Role

Parks and Public Facilities Director

*** 7. Full Address**

500 Amon Park Drive
Richland WA 99352

*** 8. Applicant Phone Number ?**

(509) 942-7664

*** 9. Applicant Email Address ?**

cwaite@ci.richland.wa.us

GRANT DETAILS

*** 10. Dollar Amount of Grant Funding Requested ?**

450,000.00

*** 11. Grant Use Type ?**

Project: Capital Improvements

12. For events or projects on City-owned property, please provide the name of the City employee you have reviewed this application with. ?

Self

*** 13. Title of the Proposed Event or Project ?**

Columbia Playfields' North Parking Lot Restoration

*** 14. Event or Project Description (will be used in the contract language if granted) ?**

Columbia Playfields is a pivotal tourism asset for the City of Richland, renowned as a high-quality softball complex that attracts players from across the region and state. This facility is a hub for numerous multi-day tournaments annually, including the prestigious state WIAA softball tournament. The north parking lot at Columbia Playfields is aging and in need of resurfacing. The City is requesting \$450,000 to supplement existing funds to resurface the parking lot, total project cost \$600,000.

Non-Grant Funding Sources and Amounts

15. Tourism Marketing - Name of Funding Source ?

SKIPPED

16. Tourism Marketing - Dollar Amount ?

SKIPPED

17. Event/Festival Marketing - Name of Funding Source ?

SKIPPED

18. Event/Festival Marketing - Dollar Amount ?

SKIPPED

19. Tourism Facility Operation - Name of Funding Source ?

City of Richland

20. Tourism Facility Operation - Dollar Amount ?

SKIPPED

* 21. TOTAL NON-GRANT FUNDING BUDGET - Dollar Amount ?

150,000.00

Grant Funding Requested - Planned Amounts and Distribution

22. Event/Festival Marketing - Dollar Amount ?

SKIPPED

23. Tourism Marketing - Dollar Amount ?

SKIPPED

24. Tourism Facility Operation - Dollar Amount ?

450,000.00

* 25. TOTAL OF GRANT FUNDS - Dollar Amount ?

450,000.00

ATTENDANCE ESTIMATES

The State of Washington **requires** attendance estimates, here are the accepted methods of calculation:

Direct Count: Actual count of visitors using methods such as paid admissions or registrations, clicker counts at entry points, vehicle counts or number of chairs filled. A direct count may also include information collected directly from businesses, such as hotels, restaurants or tour guides, likely to be affected by an event.

Indirect Count: Estimate based on information related to the number of visitors such as raffle tickets sold, redeemed discount certificates, brochures handed out, police requirements for crowd control or visual estimates.

Representative Survey: Information collected directly from individual visitors/participants. A representative survey is a highly structured data collection tool, based on a defined random sample of participants, and the results can be reliably projected to the entire population attending an event and includes margin of error and confidence level.

Informal Survey: Information collected directly from individual visitors or participants in a non-random manner that is not representative of all visitors or participants. Informal survey results cannot be projected to the entire visitor population and provide a limited indicator of attendance because not all participants had an equal chance of being included in the survey.

Structured Estimate: Estimate produced by computing known information related to the event or location. For example, one jurisdiction estimated attendance by dividing the square footage of the event area by the international building code allowance for persons (3 square feet).

* 26. Predicted Overall Attendance - Estimation Method Used ?

Indirect Count

* 27. Predicted Overall Attendance - Estimated Number ?

19,300

* 28. Predicted Attendance, 50+ Miles - Estimation Method Used ?

Indirect Count

* 29. Predicted Attendance, 50+ Miles - Estimated Number ?

13,585

* 30. Predicted Attendance, Out of State, Out of Country - Estimation Method Used ?

Indirect Count

* 31. Predicted Attendance, Out of State, Out of Country - Estimated Number ?

SKIPPED

* 32. Predicted Attendance, Paid for Overnight Lodging - Estimation Method Used ?

Indirect Count

* 33. Predicted Attendance, Paid for Overnight Lodging - Estimated Number ?

1,000

* 34. Predicted Attendance, Did Not Pay for Overnight Lodging - Estimation Method Used ?

Indirect Count

* 35. Predicted Attendance, Did Not Pay for Overnight Lodging - Estimated Number ?

12,585

36. Predicted Paid Lodging Nights - Estimation Method Used ?

Indirect Count

*** 37. Predicted Paid Lodging Nights - Estimated Number** ?

1,000

Page 4 - Conditions for Grant Approval

CONDITIONS FOR GRANT APPROVAL

38. Supplemental #1 ?

Columbia Playfields Map.pdf

39. Supplement #2 ?

****SKIPPED****

I acknowledge and agree to the below grant funding criteria:

1. I may be required to make a presentation to the advisory committee about my event/project.
2. All advertising will include the (provided) City of Richland logo and/or the phrase "Funding provided by City of Richland Lodging Tax Grant program."
3. I agree to submit marketing materials for approval by the Communications & Marketing Manager (or their designee) prior to publishing.
4. A final project report, including reporting requirements meeting state guidelines outlined in the LTAC Program Information document, and all supporting documents will be submitted to the City of Richland within 90 days of completion of the event or project AND must be expended within the calendar year in which they are granted.
5. I understand that grant progress will be monitored for compliance with scope and timeline.
6. If my event or project is on City-owned property, I have discussed this project with City staff and provided their name above.

*

40. By typing my full name below, I agree to the above grant funding requirements, that I am authorized by my agency to submit this application and that all information provided herein is true and correct. ?

Chris Waite

City of Richland - 625 Swift Blvd, MS 39 - Richland, WA 99352
www.ci.richland.wa.us/LodgingTax

**City of Richland Columbia Playfields Location
Lodging Tax Grant Application September 2024**

Columbia Playfields Central Richland indicated with 



Project Location





LODGING TAX ADVISORY COMMITTEE AGENDA ITEM ITEM COVERSHEET

Meeting Date: 10/14/2024

Agenda Category: Hotel/Motel Grant Applications

Prepared By: Christopher Waite, Parks & Public Facilities Director

Subject:

City of Richland - Columbia Point Marina Park Dock and Marina Revitalization

Department:

City Manager

Recommended Motion:

Summary:

Columbia Point Marina Park serves as a hub for various tourism-related activities, including Water 2 Wine Cruises and the IRONMAN 70.3 event. This site is central to multiple projects, such as shoreline stabilization, marina dredging, and dock replacement. The project is aimed at improving, enhancing, and preserving important public amenities. To facilitate these initiatives, the City plans to conduct permitting and maintenance of the park in 2025. The City is requesting \$400,000.

Fiscal Impact:

The City of Richland is requesting \$400,000.

Attachments:

- I. 24-018 COR - Columbia Point Dock and Marina Revitalization

Submission # 3498172
IP Address 174.231.131.3
Submission Recorded On 09/20/2024 1:54 PM
Time to Take Survey 26 minutes, 50 seconds



Please review the [LTAC Program Information](#) prior to beginning the application process.

Preview the application questions before you begin. The application is a one-time process; you cannot pause, save, or restart once you begin.

APPLICANT INFORMATION

*** 1. Name of Organization ?**

City of Richland

*** 2. Business or Agency Type**

Public Agency

*** 3. Attach Completed W-9 Form ?**

COR 2024 W-9.pdf

4. Non-Profit Agencies - Attach Proof ?

SKIPPED

*** 5. Applicant Name ?**

Director Chris Waite

6. Applicant Title or Organizational Role

Parks and Public Facilities Director

*** 7. Full Address**

500 Amon Park Drive
Richland WA 99352

*** 8. Applicant Phone Number ?**

(509) 942-7664

*** 9. Applicant Email Address ?**

cwaite@ci.richland.wa.us

GRANT DETAILS

*** 10. Dollar Amount of Grant Funding Requested ?**

400,000.00

*** 11. Grant Use Type ?**

Project: Capital Improvements

12. For events or projects on City-owned property, please provide the name of the City employee you have reviewed this application with. ?

SKIPPED

*** 13. Title of the Proposed Event or Project ?**

City of Richland Columbia Point Marina Park Dock and Marina Revitalization

*** 14. Event or Project Description (will be used in the contract language if granted) ?**

Columbia Point Marina Park serves as a hub for various tourism related activities, including Water 2 Wine Cruises and the IRONMAN 70.3 event. This site is central to multiple projects, such as shoreline stabilization, marina dredging, and dock replacement, aimed at enhancing its appeal and preserving public amenities. To facilitate these initiatives, the City plans to conduct permitting and maintenance at the park in 2025, ensuring it remains a regional attraction and a valuable resource.

Non-Grant Funding Sources and Amounts

15. Tourism Marketing - Name of Funding Source ?

SKIPPED

16. Tourism Marketing - Dollar Amount ?

SKIPPED

17. Event/Festival Marketing - Name of Funding Source ?

SKIPPED

18. Event/Festival Marketing - Dollar Amount ?

SKIPPED

19. Tourism Facility Operation - Name of Funding Source ?

SKIPPED

20. Tourism Facility Operation - Dollar Amount ?

SKIPPED

* 21. TOTAL NON-GRANT FUNDING BUDGET - Dollar Amount ?

SKIPPED

Grant Funding Requested - Planned Amounts and Distribution

22. Event/Festival Marketing - Dollar Amount ?

SKIPPED

23. Tourism Marketing - Dollar Amount ?

SKIPPED

24. Tourism Facility Operation - Dollar Amount ?

150,000.00

* 25. TOTAL OF GRANT FUNDS - Dollar Amount ?

150,000.00

ATTENDANCE ESTIMATES

The State of Washington **requires** attendance estimates, here are the accepted methods of calculation:

Direct Count: Actual count of visitors using methods such as paid admissions or registrations, clicker counts at entry points, vehicle counts or number of chairs filled. A direct count may also include information collected directly from businesses, such as hotels, restaurants or tour guides, likely to be affected by an event.

Indirect Count: Estimate based on information related to the number of visitors such as raffle tickets sold, redeemed discount certificates, brochures handed out, police requirements for crowd control or visual estimates.

Representative Survey: Information collected directly from individual visitors/participants. A representative survey is a highly structured data collection tool, based on a defined random sample of participants, and the results can be reliably projected to the entire population attending an event and includes margin of error and confidence level.

Informal Survey: Information collected directly from individual visitors or participants in a non-random manner that is not representative of all visitors or participants. Informal survey results cannot be projected to the entire visitor population and provide a limited indicator of attendance because not all participants had an equal chance of being included in the survey.

Structured Estimate: Estimate produced by computing known information related to the event or location. For example, one jurisdiction estimated attendance by dividing the square footage of the event area by the international building code allowance for persons (3 square feet).

* 26. Predicted Overall Attendance - Estimation Method Used ?

Indirect Count

* 27. Predicted Overall Attendance - Estimated Number ?

1,000

* 28. Predicted Attendance, 50+ Miles - Estimation Method Used ?

Indirect Count

* 29. Predicted Attendance, 50+ Miles - Estimated Number ?

500

* 30. Predicted Attendance, Out of State, Out of Country - Estimation Method Used ?

Indirect Count

* 31. Predicted Attendance, Out of State, Out of Country - Estimated Number ?

100

* 32. Predicted Attendance, Paid for Overnight Lodging - Estimation Method Used ?

Indirect Count

* 33. Predicted Attendance, Paid for Overnight Lodging - Estimated Number ?

10

* 34. Predicted Attendance, Did Not Pay for Overnight Lodging - Estimation Method Used ?

Indirect Count

* 35. Predicted Attendance, Did Not Pay for Overnight Lodging - Estimated Number ?

990

36. Predicted Paid Lodging Nights - Estimation Method Used ?

Indirect Count

*** 37. Predicted Paid Lodging Nights - Estimated Number** ?

30

Page 4 - Conditions for Grant Approval

CONDITIONS FOR GRANT APPROVAL

38. Supplemental #1 ?

****SKIPPED****

39. Supplement #2 ?

****SKIPPED****

I acknowledge and agree to the below grant funding criteria:

1. I may be required to make a presentation to the advisory committee about my event/project.
2. All advertising will include the (provided) City of Richland logo and/or the phrase "Funding provided by City of Richland Lodging Tax Grant program."
3. I agree to submit marketing materials for approval by the Communications & Marketing Manager (or their designee) prior to publishing.
4. A final project report, including reporting requirements meeting state guidelines outlined in the LTAC Program Information document, and all supporting documents will be submitted to the City of Richland within 90 days of completion of the event or project AND must be expended within the calendar year in which they are granted.
5. I understand that grant progress will be monitored for compliance with scope and timeline.
6. If my event or project is on City-owned property, I have discussed this project with City staff and provided their name above.

*** 40. By typing my full name below, I agree to the above grant funding requirements, that I am authorized by my agency to submit this application and that all information provided herein is true and correct.** ?

Chris Waite

City of Richland - 625 Swift Blvd, MS 39 - Richland, WA 99352
www.ci.richland.wa.us/LodgingTax



LODGING TAX ADVISORY COMMITTEE AGENDA ITEM ITEM COVERSHEET

Meeting Date: 10/14/2024

Agenda Category: Hotel/Motel Grant Applications

Prepared By: Christopher Waite, Parks & Public Facilities Director

Subject:

City of Richland - Kiosk Renew and Replace

Department:

City Manager

Recommended Motion:

Summary:

City of Richland Kiosk Renew and Replacement. These waterproof and secure kiosks will promote city events and initiatives. The City is requesting \$100,000. .

Fiscal Impact:

The City of Richland is requesting \$100,000.

Attachments:

- I. 24-017 COR - Kiosk Project

Submission # 3498104
IP Address 174.231.131.3
Submission Recorded On 09/20/2024 1:31 PM
Time to Take Survey 19 minutes, 34 seconds



Please review the [LTAC Program Information](#) prior to beginning the application process.

Preview the application questions before you begin. The application is a one-time process; you cannot pause, save, or restart once you begin.

APPLICANT INFORMATION

*** 1. Name of Organization ?**

City of Richland

*** 2. Business or Agency Type**

Public Agency

*** 3. Attach Completed W-9 Form ?**

COR 2024 W-9.pdf

4. Non-Profit Agencies - Attach Proof ?

SKIPPED

*** 5. Applicant Name ?**

Director Chris Waite

6. Applicant Title or Organizational Role

Parks and Public Facilities Director

*** 7. Full Address**

500 Amon Park Drive
Richland WA 99352

*** 8. Applicant Phone Number ?**

(509) 942-7664

*** 9. Applicant Email Address ?**

cwaite@ci.richland.wa.us

GRANT DETAILS

*** 10. Dollar Amount of Grant Funding Requested ?**

100,000.00

*** 11. Grant Use Type ?**

Project: Capital Improvements

12. For events or projects on City-owned property, please provide the name of the City employee you have reviewed this application with. ?

SKIPPED

*** 13. Title of the Proposed Event or Project ?**

City of Richland Kiosk Renew and Replace

*** 14. Event or Project Description (will be used in the contract language if granted) ?**

The City of Richland features informational kiosks at key event and tourism sites, including Howard Amon Park, Uptown, and the Parkway. These locations host popular events such as Art in the Park and Cool Desert Nights, and the kiosks serve as vital wayfinding resources for visitors. To better serve our community and enhance the visitor experience, these kiosks need refurbishing and replacement.

Non-Grant Funding Sources and Amounts

15. Tourism Marketing - Name of Funding Source ?

SKIPPED

16. Tourism Marketing - Dollar Amount ?

SKIPPED

17. Event/Festival Marketing - Name of Funding Source ?

SKIPPED

18. Event/Festival Marketing - Dollar Amount ?

SKIPPED

19. Tourism Facility Operation - Name of Funding Source ?

SKIPPED

20. Tourism Facility Operation - Dollar Amount ?

SKIPPED

* 21. TOTAL NON-GRANT FUNDING BUDGET - Dollar Amount ?

SKIPPED

Grant Funding Requested - Planned Amounts and Distribution

22. Event/Festival Marketing - Dollar Amount ?

SKIPPED

23. Tourism Marketing - Dollar Amount ?

SKIPPED

24. Tourism Facility Operation - Dollar Amount ?

100,000.00

* 25. TOTAL OF GRANT FUNDS - Dollar Amount ?

100,000.00

ATTENDANCE ESTIMATES

The State of Washington **requires** attendance estimates, here are the accepted methods of calculation:

Direct Count: Actual count of visitors using methods such as paid admissions or registrations, clicker counts at entry points, vehicle counts or number of chairs filled. A direct count may also include information collected directly from businesses, such as hotels, restaurants or tour guides, likely to be affected by an event.

Indirect Count: Estimate based on information related to the number of visitors such as raffle tickets sold, redeemed discount certificates, brochures handed out, police requirements for crowd control or visual estimates.

Representative Survey: Information collected directly from individual visitors/participants. A representative survey is a highly structured data collection tool, based on a defined random sample of participants, and the results can be reliably projected to the entire population attending an event and includes margin of error and confidence level.

Informal Survey: Information collected directly from individual visitors or participants in a non-random manner that is not representative of all visitors or participants. Informal survey results cannot be projected to the entire visitor population and provide a limited indicator of attendance because not all participants had an equal chance of being included in the survey.

Structured Estimate: Estimate produced by computing known information related to the event or location. For example, one jurisdiction estimated attendance by dividing the square footage of the event area by the international building code allowance for persons (3 square feet).

* 26. Predicted Overall Attendance - Estimation Method Used ?

Indirect Count

* 27. Predicted Overall Attendance - Estimated Number ?

5,000

* 28. Predicted Attendance, 50+ Miles - Estimation Method Used ?

Indirect Count

* 29. Predicted Attendance, 50+ Miles - Estimated Number ?

500

* 30. Predicted Attendance, Out of State, Out of Country - Estimation Method Used ?

Indirect Count

* 31. Predicted Attendance, Out of State, Out of Country - Estimated Number ?

SKIPPED

* 32. Predicted Attendance, Paid for Overnight Lodging - Estimation Method Used ?

Indirect Count

* 33. Predicted Attendance, Paid for Overnight Lodging - Estimated Number ?

10

* 34. Predicted Attendance, Did Not Pay for Overnight Lodging - Estimation Method Used ?

Indirect Count

* 35. Predicted Attendance, Did Not Pay for Overnight Lodging - Estimated Number ?

450

36. Predicted Paid Lodging Nights - Estimation Method Used ?

Indirect Count

*** 37. Predicted Paid Lodging Nights - Estimated Number** ?

10

Page 4 - Conditions for Grant Approval

CONDITIONS FOR GRANT APPROVAL

38. Supplemental #1 ?

****SKIPPED****

39. Supplement #2 ?

****SKIPPED****

I acknowledge and agree to the below grant funding criteria:

1. I may be required to make a presentation to the advisory committee about my event/project.
2. All advertising will include the (provided) City of Richland logo and/or the phrase "Funding provided by City of Richland Lodging Tax Grant program."
3. I agree to submit marketing materials for approval by the Communications & Marketing Manager (or their designee) prior to publishing.
4. A final project report, including reporting requirements meeting state guidelines outlined in the LTAC Program Information document, and all supporting documents will be submitted to the City of Richland within 90 days of completion of the event or project AND must be expended within the calendar year in which they are granted.
5. I understand that grant progress will be monitored for compliance with scope and timeline.
6. If my event or project is on City-owned property, I have discussed this project with City staff and provided their name above.

*

40. By typing my full name below, I agree to the above grant funding requirements, that I am authorized by my agency to submit this application and that all information provided herein is true and correct. ?

Chris Waite

City of Richland - 625 Swift Blvd, MS 39 - Richland, WA 99352
www.ci.richland.wa.us/LodgingTax



LODGING TAX ADVISORY COMMITTEE AGENDA ITEM ITEM COVERSHEET

Meeting Date: 10/14/2024

Agenda Category: Hotel/Motel Grant Applications

Prepared By: Christopher Waite, Parks & Public Facilities Director

Subject:

City of Richland - Side by Side

Department:

City Manager

Recommended Motion:

Summary:

The City of Richland is requesting to expand its fleet to assist with regional events. Currently, the Parks and Public Facilities department's fleet consists primarily of full-sized pickups. To better support events, the City plans to purchase a dedicated event/tournament side-by-side vehicle. The City is requesting \$49,000.

Fiscal Impact:

The City of Richland is requesting \$49,000.

Attachments:

- I. 24-014 COR - Side by Side Event

Submission # 3497325
IP Address 174.231.131.3
Submission Recorded On 09/17/2024 3:56 PM
Time to Take Survey 2 days, 55 minutes, 50 seconds



Please review the [LTAC Program Information](#) prior to beginning the application process.

Preview the application questions before you begin. The application is a one-time process; you cannot pause, save, or restart once you begin.

APPLICANT INFORMATION

*** 1. Name of Organization ?**

City of Richland

*** 2. Business or Agency Type**

Public Agency

*** 3. Attach Completed W-9 Form ?**

COR 2024 W-9.pdf

4. Non-Profit Agencies - Attach Proof ?

SKIPPED

*** 5. Applicant Name ?**

Director Chris Waite

6. Applicant Title or Organizational Role

Parks and Public Facilities Director

*** 7. Full Address**

500 Amon Park Drive
Richland WA 99352

*** 8. Applicant Phone Number ?**

(509) 942-7664

*** 9. Applicant Email Address ?**

cwaite@ci.richland.wa.us

GRANT DETAILS

*** 10. Dollar Amount of Grant Funding Requested ?**

49,000.00

*** 11. Grant Use Type ?**

Project: Capital Improvements

12. For events or projects on City-owned property, please provide the name of the City employee you have reviewed this application with. ?

SKIPPED

*** 13. Title of the Proposed Event or Project ?**

City of Richland Event Side by Side

*** 14. Event or Project Description (will be used in the contract language if granted) ?**

The City of Richland hosts and facilitates a variety of events and tournaments each year, including softball tournaments, See 3 Slam, Art in the Park, and Cool Desert Nights. Often, the crowd size or event layout requires a small vehicle to effectively address various needs. Currently, the Parks and Public Facilities department's fleet consists primarily of full-sized pickups. To better support events, the City plans to purchase a dedicated event/tournament side-by-side vehicle.

Non-Grant Funding Sources and Amounts

15. Tourism Marketing - Name of Funding Source ?

SKIPPED

16. Tourism Marketing - Dollar Amount ?

SKIPPED

17. Event/Festival Marketing - Name of Funding Source ?

SKIPPED

18. Event/Festival Marketing - Dollar Amount ?

SKIPPED

19. Tourism Facility Operation - Name of Funding Source ?

SKIPPED

20. Tourism Facility Operation - Dollar Amount ?

SKIPPED

* 21. TOTAL NON-GRANT FUNDING BUDGET - Dollar Amount ?

SKIPPED

Grant Funding Requested - Planned Amounts and Distribution

22. Event/Festival Marketing - Dollar Amount ?

SKIPPED

23. Tourism Marketing - Dollar Amount ?

SKIPPED

24. Tourism Facility Operation - Dollar Amount ?

SKIPPED

* 25. TOTAL OF GRANT FUNDS - Dollar Amount ?

49,000.00

ATTENDANCE ESTIMATES

The State of Washington **requires** attendance estimates, here are the accepted methods of calculation:

Direct Count: Actual count of visitors using methods such as paid admissions or registrations, clicker counts at entry points, vehicle counts or number of chairs filled. A direct count may also include information collected directly from businesses, such as hotels, restaurants or tour guides, likely to be affected by an event.

Indirect Count: Estimate based on information related to the number of visitors such as raffle tickets sold, redeemed discount certificates, brochures handed out, police requirements for crowd control or visual estimates.

Representative Survey: Information collected directly from individual visitors/participants. A representative survey is a highly structured data collection tool, based on a defined random sample of participants, and the results can be reliably projected to the entire population attending an event and includes margin of error and confidence level.

Informal Survey: Information collected directly from individual visitors or participants in a non-random manner that is not representative of all visitors or participants. Informal survey results cannot be projected to the entire visitor population and provide a limited indicator of attendance because not all participants had an equal chance of being included in the survey.

Structured Estimate: Estimate produced by computing known information related to the event or location. For example, one jurisdiction estimated attendance by dividing the square footage of the event area by the international building code allowance for persons (3 square feet).

* 26. Predicted Overall Attendance - Estimation Method Used ?

Indirect Count

* 27. Predicted Overall Attendance - Estimated Number ?

40,000

* 28. Predicted Attendance, 50+ Miles - Estimation Method Used ?

Indirect Count

* 29. Predicted Attendance, 50+ Miles - Estimated Number ?

15,000

* 30. Predicted Attendance, Out of State, Out of Country - Estimation Method Used ?

Indirect Count

* 31. Predicted Attendance, Out of State, Out of Country - Estimated Number ?

SKIPPED

* 32. Predicted Attendance, Paid for Overnight Lodging - Estimation Method Used ?

Indirect Count

* 33. Predicted Attendance, Paid for Overnight Lodging - Estimated Number ?

10

* 34. Predicted Attendance, Did Not Pay for Overnight Lodging - Estimation Method Used ?

Indirect Count

* 35. Predicted Attendance, Did Not Pay for Overnight Lodging - Estimated Number ?

39,000

36. Predicted Paid Lodging Nights - Estimation Method Used ?

Indirect Count

*** 37. Predicted Paid Lodging Nights - Estimated Number** ?

10

Page 4 - Conditions for Grant Approval

CONDITIONS FOR GRANT APPROVAL

38. Supplemental #1 ?

****SKIPPED****

39. Supplement #2 ?

****SKIPPED****

I acknowledge and agree to the below grant funding criteria:

1. I may be required to make a presentation to the advisory committee about my event/project.
2. All advertising will include the (provided) City of Richland logo and/or the phrase "Funding provided by City of Richland Lodging Tax Grant program."
3. I agree to submit marketing materials for approval by the Communications & Marketing Manager (or their designee) prior to publishing.
4. A final project report, including reporting requirements meeting state guidelines outlined in the LTAC Program Information document, and all supporting documents will be submitted to the City of Richland within 90 days of completion of the event or project AND must be expended within the calendar year in which they are granted.
5. I understand that grant progress will be monitored for compliance with scope and timeline.
6. If my event or project is on City-owned property, I have discussed this project with City staff and provided their name above.

*

40. By typing my full name below, I agree to the above grant funding requirements, that I am authorized by my agency to submit this application and that all information provided herein is true and correct. ?

Chris Waite

City of Richland - 625 Swift Blvd, MS 39 - Richland, WA 99352
www.ci.richland.wa.us/LodgingTax



LODGING TAX ADVISORY COMMITTEE AGENDA ITEM ITEM COVERSHEET

Meeting Date: 10/14/2024

Agenda Category: Hotel/Motel Grant Applications

Prepared By: Nicholas Tabor

Subject:

Richland Chamber of Commerce - Cool Desert Nights

Department:

City Manager

Recommended Motion:

Summary:

Cool Desert Nights is a two day event that includes a car cruise/parade, Party in the Park with live music and a Show N Shine. The Richland Chamber of Commerce is requesting \$25,000 and has a total non-grant funding budget of \$72,100.

Fiscal Impact:

The Richland Chamber of Commerce is requesting \$25,000.

Attachments:

- I. Richland Chamber of Commerce - Cool Desert Nights

Submission # 3493694
IP Address 71.84.176.30
Submission Recorded On 09/18/2024 3:47 PM
Time to Take Survey 8 minutes, 58 seconds



Please review the [LTAC Program Information](#) prior to beginning the application process.

Preview the application questions before you begin. The application is a one-time process; you cannot pause, save, or restart once you begin.

APPLICANT INFORMATION

* 1. Name of Organization ?

Richland Chamber of Commerce

* 2. Business or Agency Type

Non-Profit

* 3. Attach Completed W-9 Form ?

SKM_C30824091716010.pdf

4. Non-Profit Agencies - Attach Proof ?

SKM_C30824091716022.pdf

* 5. Applicant Name ?

Nicholas Tabor

6. Applicant Title or Organizational Role

Event Chair

* 7. Full Address

225 Wellsian Way # B
Richland WA 99352

* 8. Applicant Phone Number ?

(509) 845-6365

* 9. Applicant Email Address ?

nick@welchheatingandac.com

GRANT DETAILS

* 10. Dollar Amount of Grant Funding Requested ?

25,000.00

* 11. Grant Use Type ?

Event: on City-owned Property or Facility

12. For events or projects on City-owned property, please provide the name of the City employee you have reviewed this application with. ?

Julie Piper, Stan Johnson, Gail Everett

* 13. Title of the Proposed Event or Project ?

Cool Desert Nights

* 14. Event or Project Description (will be used in the contract language if granted) ?

Cool Desert Nights is an iconic event 31 years running. On day one of the event, we have a car cruise/parade and Party in the Park. On day two, we have the Show and Shine, a car show. We intend on providing live entertainment, vendors, and an award show. This event is run primarily through volunteers.

Non-Grant Funding Sources and Amounts

15. Tourism Marketing - Name of Funding Source ?

SKIPPED

16. Tourism Marketing - Dollar Amount ?

SKIPPED

17. Event/Festival Marketing - Name of Funding Source ?

Sponsorships - Vendors Unknown

18. Event/Festival Marketing - Dollar Amount ?

20,000.00

19. Tourism Facility Operation - Name of Funding Source ?

SKIPPED

20. Tourism Facility Operation - Dollar Amount ?

SKIPPED

*** 21. TOTAL NON-GRANT FUNDING BUDGET - Dollar Amount ?**

72,100.00

Grant Funding Requested - Planned Amounts and Distribution

22. Event/Festival Marketing - Dollar Amount ?

25,000.00

23. Tourism Marketing - Dollar Amount ?

SKIPPED

24. Tourism Facility Operation - Dollar Amount ?

SKIPPED

*** 25. TOTAL OF GRANT FUNDS - Dollar Amount ?**

25,000.00

Page 3 - Attendance Estimates

ATTENDANCE ESTIMATES

The State of Washington **requires** attendance estimates, here are the accepted methods of calculation:

Direct Count: Actual count of visitors using methods such as paid admissions or registrations, clicker counts at entry points, vehicle counts or number of chairs filled. A direct count may also include information collected directly from businesses, such as hotels, restaurants or tour guides, likely to be affected by an event.

Indirect Count: Estimate based on information related to the number of visitors such as raffle tickets sold, redeemed discount certificates, brochures handed out, police requirements for crowd control or visual estimates.

Representative Survey: Information collected directly from individual visitors/participants. A representative survey is a highly structured data collection tool, based on a defined random sample of participants, and the results can be reliably projected to the entire population attending an event and includes margin of error and confidence level.

Informal Survey: Information collected directly from individual visitors or participants in a non-random manner that is not representative of all visitors or participants. Informal survey results cannot be projected to the entire visitor population and provide a limited indicator of attendance because not all participants had an equal chance of being included in the survey.

Structured Estimate: Estimate produced by computing known information related to the event or location. For example, one jurisdiction estimated attendance by dividing the square footage of the event area by the international building code allowance for persons (3 square feet).

*** 26. Predicted Overall Attendance - Estimation Method Used ?**

Indirect Count

*** 27. Predicted Overall Attendance - Estimated Number ?**

6,000

*** 28. Predicted Attendance, 50+ Miles - Estimation Method Used ?**

Indirect Count

*** 29. Predicted Attendance, 50+ Miles - Estimated Number ?**

1,500

*** 30. Predicted Attendance, Out of State, Out of Country - Estimation Method Used ?**

Indirect Count

*** 31. Predicted Attendance, Out of State, Out of Country - Estimated Number ?**

500

*** 32. Predicted Attendance, Paid for Overnight Lodging - Estimation Method Used ?**

Indirect Count

*** 33. Predicted Attendance, Paid for Overnight Lodging - Estimated Number ?**

1,500

*** 34. Predicted Attendance, Did Not Pay for Overnight Lodging - Estimation Method Used ?**

Indirect Count

*** 35. Predicted Attendance, Did Not Pay for Overnight Lodging - Estimated Number ?**

4,500

36. Predicted Paid Lodging Nights - Estimation Method Used ?

Indirect Count

* **37. Predicted Paid Lodging Nights - Estimated Number** ?

1,500

Page 4 - Conditions for Grant Approval

CONDITIONS FOR GRANT APPROVAL

38. Supplemental #1 ?

Preliminary Event Budget.pdf

39. Supplement #2 ?

2024 Event Photos.pdf

I acknowledge and agree to the below grant funding criteria:

1. I may be required to make a presentation to the advisory committee about my event/project.
2. All advertising will include the (provided) City of Richland logo and/or the phrase "Funding provided by City of Richland Lodging Tax Grant program."
3. I agree to submit marketing materials for approval by the Communications & Marketing Manager (or their designee) prior to publishing.
4. A final project report, including reporting requirements meeting state guidelines outlined in the LTAC Program Information document, and all supporting documents will be submitted to the City of Richland within 90 days of completion of the event or project AND must be expended within the calendar year in which they are granted.
5. I understand that grant progress will be monitored for compliance with scope and timeline.
6. If my event or project is on City-owned property, I have discussed this project with City staff and provided their name above.

*

40. By typing my full name below, I agree to the above grant funding requirements, that I am authorized by my agency to submit this application and that all information provided herein is true and correct. ?

Jarrold Miller

City of Richland - 625 Swift Blvd, MS 39 - Richland, WA 99352

www.ci.richland.wa.us/LodgingTax

Preliminary Event Budget	2024 Event	2025 Projected Budget
Contractor: Event Coordinator	5,017.50	10,000.00
Operational Supplies	3,116.43	6,200.00
Insurance	713.00	800.00
Restrooms, Parking Plan, and Traffic Control Plan		15,000.00
Live Entertainment		10,000.00
Volunteer Hospitality		1,000.00
Marketing		
Promotional Materials	4,876.93	10,000.00
Signage and Staging	1,647.50	3,000.00
Volunteer Shirts	928.62	1,100.00
Website Development	1,630.50	2,000.00
Radio Advertisements	5,465.00	6,500.00
TV Advertisements	3,000.00	3,600.00
Printed Materials	737.00	900.00
Fees	1,605.98	2,000.00
Total Event Costs	28,738.46	72,132.86
Requested Funding	19,891.53	25,000.00

The Richland Chamber of Commerce first hosted Cool Desert Nights in 2024. Looking forward to 2025, our event committee has ideas on how to grow and improve the event. First, Cool Desert Nights will be open for motorcycles. We anticipate a 20% growth in vehicle registrations due to motorcycle owners attending Hogs and Dogs annual bike rally the day before the start of Cool Desert Nights. It is our hope that overall attendance will grow 20% as well. To improve programming at the event, we will be looking to add live entertainment. We will also be providing a volunteer hospitality tent, something we were not able to do this year.

COOL
DESERT NIGHTS

THANK YOU!

Save The Date
2025 Cool Desert Nights
June 27th & 28th

WWW.RICHLANDCHAMBER.ORG

Thank you to our sponsors, Town Square Media, Rattlesnake Jeep Club, Covair Club, Cruise/ Registration/Judges/Saturday parking volunteers, Richland Parks & Rec, Stan Johnson, Julie Piper, Dave Rose, May Hays, Rob Welch, Jarrod Miller, Chandra Christenson, Horn Rapids RV, CBC Nursing staff, Richland Fire & Police, all the vendors, Richland Kiwanis Club, & all the car/truck owners that work tirelessly to bring their rides out for this annual event.



COOL DESERT NIGHTS

is Back In Richland!



SAVE THE DATE



THANK YOU!

Save the Date
2025 Cool Desert Nights
June 27th & 28th
WWW.RICHLANDCHAMBER.ORG

Thank you to our sponsors, Town Square Media, Rattlesnake Jeep Club, Covair Club, Cruise/Registration/Judges/Saturday parking volunteers, Richland Parks & Rec, Stan Johnson, Julie Piper, Dave Rose, May Hays, Rob Welch, Jarrod Miller, Chandra Christenson, Horn Rapids RV, CBC Nursing staff, Richland



Cool Desert Nights 2025 will be Friday, June 27th and Saturday, June 28th. Stay tuned for more details!

2024 Cool Desert Nights Information

cool **DESERT NIGHTS** **FREE FOR PUBLIC** **WEEKEND LINE UP**
JUNE 21ST-22ND RICHLAND

FRIDAY JUNE 21ST, 2024

12-7pm Registration pick up and late registration. all car/cruise participants must pick up their swag bag and registration packet with your dash pass. **Richland City Hall (look for flags)**

4-6pm Cruise participants staging. **Richland City Hall/Federal Building lot (625 Swift Blvd, Richland, WA)**

6pm Cruise starts! **NEW ROUTE!** Cars will be cruising on George Washington Way only till 7pm!. **George Washington Way**

5:30pm **"Party In The Park"** Live music 7-9pm by Fastlane an Eagles tribute band, 21+ beer & wine garden, food vendors. **John Dam Plaza**

SATURDAY JUNE 22ND, 2024

6:30a-8:30 Vendor & Merchants set up. Enter off Symons Street. **Uptown Shopping Center**

6:30a-9 **REGISTERED** participants may start parking **Entry from Symons to Jefferson Park.**

6:30am Late Registration starts, enter off Williams St., park in south parking lot to register then proceed to Show n Shine area in the Uptown Plaza.

7-11am Richland Kiwanis Pancake Feed **Jefferson Park**

9-4pm **2024 Cool Desert Nights Show n Shine Kids Zone, Food, Merchants, Music!**

3pm HAPO Community Credit Union Cool Desert Nights Awards Ceremony at main stage.

Logos: RICHLAND CHAMBER, PORT OF BENTON, IBEW 112, HAPO Community Credit Union, Richland

www.richlandchamber.org 509-987-4003 Follow Richland Chamber of Commerce on Facebook

cool **DESERT NIGHTS** **PARTY IN THE PARK**

FRIDAY, JUNE 21, 2024
 5:30 - 9 p.m. | HAPO Stage @John Dam Plaza

LIVE MUSIC from 7-9 p.m.
Fastlane
 performing music by The Eagles

CAR CRUISE from 6-7 p.m.

- Free Entry
- Food Trucks
- Beer Garden for 21+ hosted by TC Sunrise Rotary

Bring your chairs and blankets and enjoy the show!

Early registration for your car/truck is over. If you would like to register you will need to go to City Hall on Friday, June 21st from 12-7pm to complete a late registration entry. Look for the flags. You may also register Saturday June 22nd at 6:30am at the Uptown Plaza (enter off Williams.) Late registration is \$45 (Cruise+ Show N Shine), \$25 Cruise only, \$25 additional car.

This event is FREE and open to the public to attend. Registration is required to be a part of the Cruise and Show N Shine.

Cool Desert Nights FAQ's

Q. I can't register online, what's wrong?

A. Early online registration ended 6/17. You will now have to wait until Friday 6/21. Noon-7pm at Richland City Hall look for the flags OR Saturday, 6/22 at the Uptown Plaza.

Q. How much is Party in the Park?

A. FREE...the entire time. DJ 5:30-7, FastLane, an Eagles tribute live band 7-9pm.

Q. Are there vendors at Party in the Park?

A. Yes! Totally different vendors than Saturday as well as 21+ beer garden.

Q. Where is Party in the Park?

A. John Dam Plaza

Q. How much is late registration?

A. \$45 Cruise + Show N Shine, \$25 Cruise only, \$25 additional car.

Q. When do I pick up my registration packet with my dash pass and goody bag?

A. Friday 6/21, noon-7pm at Richland City Hall.

Q. Can we throw candy from our cars during the cruise?

A. Sorry, no. This years cruise route will have 2-way traffic and RPD advised us to spread the word that this could be dangerous.

Q. What is the cruise route?

A. See above.

Q. Is there a pancake breakfast Saturday?

A. YES! Richland Kiwanis is hosting this event from 7-11am in Jefferson Park. Cash only!

Q. Will there be motorcycles?

A. No, sorry not this year. We are hoping to add the back in upcoming years.

Q. When do we line up for the cruise?

A. 4-6pm Friday 6/21 and the Richland Federal Hall/City Hall parking lot.

Please stay connected and informed by following our [Facebook](#) and [Instagram](#).

Questions contact the Richland Chamber of Commerce at (509) 987-4003 or

via email at information@richlandchamber.org

We are *no longer accepting vendors* for Cool Desert Nights.





UPTOWN
30 YEAR ANNIVERSARY

JUNE 21 & 22

PREMIER SPONSOR
IBEW 112
LOCAL 112

cool

DESERT NIGHTS

CRUISIN' 24'

Cruise & Party in the Park

JOHN DAM PLAZA

FRI
6PM - 9PM

KIWANIS PANCAKE FEED

7AM - 11AM

SHOW N SHINE

SAT
9AM to 4PM

FOR MORE INFORMATION:
509-987-4003
WWW.RICHLANDCHAMBER.ORG

Sponsors







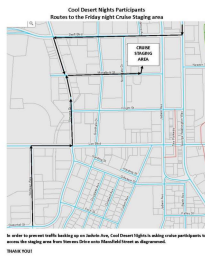



PANCAKE BREAKFAST

JOIN US FOR DELICIOUS FOOD AND A GREAT CAUSE!





Cool Desert Nights Information



Cool Desert Night Sponsors





LODGING TAX ADVISORY COMMITTEE AGENDA ITEM ITEM COVERSHEET

Meeting Date: 10/14/2024

Agenda Category: Hotel/Motel Grant Applications

Prepared By: Kevin Lewis

Subject:

Visit Tri-Cities - IRONMAN 70.3 Washington Tri-Cities

Department:

City Manager

Recommended Motion:

Summary:

The second Ironman 70.3 is coming in late September 2025. The funds requested will be used to create and distribute multi-media assets to market and showcase the event and the destination. They are requesting \$30,000 and have listed an operating budget of \$200,000.

Fiscal Impact:

Visit Tri-Cities is requesting \$30,000.

Attachments:

- I. Visit Tri-Cities - IRONMAN 70.3 Washington Tri-Cities



2025 Lodging Tax Grant Application

Please review the [LTAC Program Information](#) prior to beginning the application process.

Preview the [application questions before you begin.](#) The application is a one-time process; you cannot pause, save, or restart once you begin.

APPLICANT INFORMATION

***1. Name of Organization**

Visit Tri-Cities

***2. Business or Agency Type**

Non-Profit

***3. Attach Completed W-9 Form**

TC Visitor & Conv Bureau dba Visti TC W-9.pdf

4. Non-Profit Agencies - Attach Proof

Letter of Determination Tax Exempt Status.pdf

***5. Applicant Name**

CEO Kevin Lewis

6. Applicant Title or Organizational Role

CEO & President

***7. Full Address**

7130 W Grandridge Blvd
B
Kennewick WA 99336

***8. Applicant Phone Number**

(509) 735-8486

***9. Applicant Email Address**

Kevin@VisitTri-Cities.com

GRANT DETAILS

***10. Dollar Amount of Grant Funding Requested**

30,000.00

***11. Grant Use Type**

Event: on City-owned Property or Facility

12. For events or projects on City-owned property, please provide the name of the City employee you have reviewed this application with.

Julie Piper

***13. Title of the Proposed Event or Project**

IRONMAN 70.3 Washington Tri-Cities - Media Production, Marketing, and Volunteer Celebration

***14. Event or Project Description (will be used in the contract language if granted)**

These funds will be used to create and distribute multi-media assets to market and showcase the event and the destination. These assets will celebrate the community involvement, volunteer spirit and enthusiasm that make the destination such a great place to visit. We will also use the multi-media assets locally to energize our communities and recruit support for the event. Funds will also be used to produce a volunteer appreciation event.

Non-Grant Funding Sources and Amounts

15. Tourism Marketing - Name of Funding Source

Visit Tri-Cities & IRONAMN

16. Tourism Marketing - Dollar Amount

100,000.00

17. Event/Festival Marketing - Name of Funding Source

Visit Tri-Cities & IRONMAN

18. Event/Festival Marketing - Dollar Amount

100,000.00

19. Tourism Facility Operation - Name of Funding Source

SKIPPED

20. Tourism Facility Operation - Dollar Amount

SKIPPED

***21. TOTAL NON-GRANT FUNDING BUDGET - Dollar Amount**

200,000.00

Grant Funding Requested - Planned Amounts and Distribution

22. Event/Festival Marketing - Dollar Amount

30,000.00

23. Tourism Marketing - Dollar Amount

SKIPPED

24. Tourism Facility Operation - Dollar Amount

SKIPPED

***25. TOTAL OF GRANT FUNDS - Dollar Amount**

30,000.00

ATTENDANCE ESTIMATES

The State of Washington **requires** attendance estimates, here are the accepted methods of calculation:

Direct Count: Actual count of visitors using methods such as paid admissions or registrations, clicker counts at entry points, vehicle counts or number of chairs filled. A direct count may also include information collected directly from businesses, such as hotels, restaurants or tour guides, likely to be affected by an event.

Indirect Count: Estimate based on information related to the number of visitors such as raffle tickets sold, redeemed discount certificates, brochures handed out, police requirements for crowd control or visual estimates.

Representative Survey: Information collected directly from individual visitors/participants. A representative survey is a highly structured data collection tool, based on a defined random sample of participants, and the results can be reliably projected to the entire population attending an event and includes margin of error and confidence level.

Informal Survey: Information collected directly from individual visitors or participants in a non-random manner that is not representative of all visitors or participants. Informal survey results cannot be projected to the entire visitor population and provide a limited indicator of attendance because not all participants had an equal chance of being included in the survey.

Structured Estimate: Estimate produced by computing known information related to the event or location. For example, one jurisdiction estimated attendance by dividing the square footage of the event area by the international building code allowance for persons (3 square feet).

***26. Predicted Overall Attendance - Estimation Method Used**

Structured Estimate

***27. Predicted Overall Attendance - Estimated Number**

10,000

***28. Predicted Attendance, 50+ Miles - Estimation Method Used**

Structured Estimate

***29. Predicted Attendance, 50+ Miles - Estimated Number**

9,000

***30. Predicted Attendance, Out of State, Out of Country - Estimation Method Used**

Structured Estimate

***31. Predicted Attendance, Out of State, Out of Country - Estimated Number**

7,000

***32. Predicted Attendance, Paid for Overnight Lodging - Estimation Method Used**

Structured Estimate

***33. Predicted Attendance, Paid for Overnight Lodging - Estimated Number**

9,000

***34. Predicted Attendance, Did Not Pay for Overnight Lodging - Estimation Method Used**

Structured Estimate

***35. Predicted Attendance, Did Not Pay for Overnight Lodging - Estimated Number**

1,000

36. Predicted Paid Lodging Nights - Estimation Method Used

Structured Estimate

***37. Predicted Paid Lodging Nights - Estimated Number**

10,000

CONDITIONS FOR GRANT APPROVAL

38. Supplemental #1
LTAC Grant Supplemental.pdf

39. Supplement #2
SKIPPED

I acknowledge and agree to the below grant funding criteria:

1. I may be required to make a presentation to the advisory committee about my event/project.
2. All advertising will include the (provided) City of Richland logo and/or the phrase "Funding provided by City of Richland Lodging Tax Grant program."
3. I agree to submit marketing materials for approval by the Communications & Marketing Manager (or their designee) prior to publishing.
4. A final project report, including reporting requirements meeting state guidelines outlined in the LTAC Program Information document, and all supporting documents will be submitted to the City of Richland within 90 days of completion of the event or project AND must be expended within the calendar year in which they are granted.
5. I understand that grant progress will be monitored for compliance with scope and timeline.
6. If my event or project is on City-owned property, I have discussed this project with City staff and provided their name above.

***40. By typing my full name below, I agree to the above grant funding requirements, that I am authorized by my agency to submit this application and that all information provided herein is true and correct.**

Kevin Lewis

City of Richland - 625 Swift Blvd, MS 39 - Richland, WA 99352
www.ci.richland.wa.us/LodgingTax



7130 W. Grandridge Blvd., Suite B
Kennewick, WA 99336
509-735-8486
1-800-254-5824
www.VisitTRI-CITIES.com
info@VisitTRI-CITIES.com

September 4, 2024

City of Richland,

As we gear up for this year's IRONMAN 70.3 Washington Tri-Cities, we are thrilled to report that activities leading up to the event have been extremely successful. Over 3,000 athletes have registered, and we anticipate 10,000 visitors, including staff and supporters will be here for the weekend of September 22nd. The enthusiasm and energy surrounding the event have been rewarding, and we are eager to continue this momentum into the next year.

This year's IRONMAN 70.3 is projected to bring an economic impact of \$8-\$10 million to the Tri-Cities. This significant contribution to our local economy underscores the importance of sustaining and growing the event in partnership with the City of Richland.

Our community's response has been overwhelmingly positive. The marketing initiatives funded by this year's lodging tax grant have been instrumental in driving awareness and engagement. Highlighting local jurisdiction and community leaders, as well as athletes, has not only increased visibility but also fostered a strong sense of pride and involvement within the community. As a testament to this, we have already filled the majority of our 1,000 volunteer slots, reflecting the community's eagerness to be part of this prestigious event.

To build on this year's achievements, we are seeking \$30,000 in lodging tax funds for the upcoming year. These funds will be allocated towards further marketing efforts, allowing us to continue promoting Richland as a prime destination for athletes and visitors alike. Additionally, we plan to expand our volunteer celebration to recognize and honor the invaluable contributions of those who dedicate their time and energy to make IRONMAN 70.3 a success.

We value the City of Richland's continued partnership and support. The enthusiastic engagement of community leaders, agencies and staff has been essential in bringing this event to life. Funds from this grant will leverage substantial financial commitments already being made by Visit Tri-Cities, IRONMAN and the City of Richland to help ensure that IRONMAN 70.3 not only remains a highlight on the community calendar but also continues to drive significant economic and social benefits for years to come.

With much appreciation,

A handwritten signature in blue ink, appearing to read "Kevin Lewis".

Kevin Lewis
President & CEO





LODGING TAX ADVISORY COMMITTEE AGENDA ITEM ITEM COVERSHEET

Meeting Date: 10/14/2024

Agenda Category: Hotel/Motel Grant Applications

Prepared By: Trevor Kilgannon

Subject:

Three Rivers Ultimate - Hanford Howl 2025

Department:

City Manager

Recommended Motion:

Summary:

The Hanford Howl is an Ultimate Frisbee tournament hosted by Three Rivers Ultimate, in Richland, WA as a fundraiser for the Special Olympics of Washington. The event is in late October. They are requesting \$10,000 out of a projected \$37,400 budget.

Fiscal Impact:

Three Rivers Ultimate is requesting \$10,000.

Attachments:

- I. Three Rivers Ultimate - Hanford Howl 2025



2025 Lodging Tax Grant Application

Please review the [LTAC Program Information](#) prior to beginning the application process.

Preview the application questions before you begin. The application is a one-time process; you cannot pause, save, or restart once you begin.

APPLICANT INFORMATION

***1. Name of Organization**

Three Rivers Ultimate

***2. Business or Agency Type**

Non-Profit

***3. Attach Completed W-9 Form**

TRUw9.pdf

4. Non-Profit Agencies - Attach Proof

IRS_TRU_Nonprofit_determination.pdf

***5. Applicant Name**

Trevor Kilgannon

6. Applicant Title or Organizational Role

Executive Director

***7. Full Address**

PO BOX 1232
Richland WA 99352

***8. Applicant Phone Number**

(206) 618-7403

***9. Applicant Email Address**

threeriversultimate@gmail.com

GRANT DETAILS

***10. Dollar Amount of Grant Funding Requested**

10,000.00

***11. Grant Use Type**

Event

12. For events or projects on City-owned property, please provide the name of the City employee you have reviewed this application with.

N/A

***13. Title of the Proposed Event or Project**

Hanford Howl 2025

***14. Event or Project Description (will be used in the contract language if granted)**

The Hanford Howl is an Ultimate frisbee tournament hosted by Three Rivers Ultimate, in Richland, WA as a fundraiser for the Special Olympics of Washington. The mission of the Hanford Howl is to promote charity, community building, and spirited competition through the sport of Ultimate, while dressed in creative team-themed costumes. All proceeds are donated to Special Olympics of Washington, Three Rivers Ultimate, and to the charities chosen by each of our bracket winners.

Non-Grant Funding Sources and Amounts

15. Tourism Marketing - Name of Funding Source

N/A

16. Tourism Marketing - Dollar Amount

SKIPPED

17. Event/Festival Marketing - Name of Funding Source

N/A

18. Event/Festival Marketing - Dollar Amount

SKIPPED

19. Tourism Facility Operation - Name of Funding Source

Registration, Merchandise sales, additional donations

20. Tourism Facility Operation - Dollar Amount

37,400.00

***21. TOTAL NON-GRANT FUNDING BUDGET - Dollar Amount**

37,400.00

Grant Funding Requested - Planned Amounts and Distribution

22. Event/Festival Marketing - Dollar Amount

SKIPPED

23. Tourism Marketing - Dollar Amount

SKIPPED

24. Tourism Facility Operation - Dollar Amount

10,000.00

***25. TOTAL OF GRANT FUNDS - Dollar Amount**

10,000.00

ATTENDANCE ESTIMATES

The State of Washington **requires** attendance estimates, here are the accepted methods of calculation:

Direct Count: Actual count of visitors using methods such as paid admissions or registrations, clicker counts at entry points, vehicle counts or number of chairs filled. A direct count may also include information collected directly from businesses, such as hotels, restaurants or tour guides, likely to be affected by an event.

Indirect Count: Estimate based on information related to the number of visitors such as raffle tickets sold, redeemed discount certificates, brochures handed out, police requirements for crowd control or visual estimates.

Representative Survey: Information collected directly from individual visitors/participants. A representative survey is a highly structured data collection tool, based on a defined random sample of participants, and the results can be reliably projected to the entire population attending an event and includes margin of error and confidence level.

Informal Survey: Information collected directly from individual visitors or participants in a non-random manner that is not representative of all visitors or participants. Informal survey results cannot be projected to the entire visitor population and provide a limited indicator of attendance because not all participants had an equal chance of being included in the survey.

Structured Estimate: Estimate produced by computing known information related to the event or location. For example, one jurisdiction estimated attendance by dividing the square footage of the event area by the international building code allowance for persons (3 square feet).

***26. Predicted Overall Attendance - Estimation Method Used**

Direct Count

***27. Predicted Overall Attendance - Estimated Number**

783

***28. Predicted Attendance, 50+ Miles - Estimation Method Used**

Direct Count

***29. Predicted Attendance, 50+ Miles - Estimated Number**

748

***30. Predicted Attendance, Out of State, Out of Country - Estimation Method Used**

Indirect Count

***31. Predicted Attendance, Out of State, Out of Country - Estimated Number**

50

***32. Predicted Attendance, Paid for Overnight Lodging - Estimation Method Used**

Direct Count

***33. Predicted Attendance, Paid for Overnight Lodging - Estimated Number**

748

***34. Predicted Attendance, Did Not Pay for Overnight Lodging - Estimation Method Used**

Direct Count

***35. Predicted Attendance, Did Not Pay for Overnight Lodging - Estimated Number**

35

36. Predicted Paid Lodging Nights - Estimation Method Used

Direct Count

***37. Predicted Paid Lodging Nights - Estimated Number**

284

CONDITIONS FOR GRANT APPROVAL

38. Supplemental #1
2025 Hanford Howl Supplemental Information.pdf

39. Supplement #2
SKIPPED

I acknowledge and agree to the below grant funding criteria:

1. I may be required to make a presentation to the advisory committee about my event/project.
2. All advertising will include the (provided) City of Richland logo and/or the phrase "Funding provided by City of Richland Lodging Tax Grant program."
3. I agree to submit marketing materials for approval by the Communications & Marketing Manager (or their designee) prior to publishing.
4. A final project report, including reporting requirements meeting state guidelines outlined in the LTAC Program Information document, and all supporting documents will be submitted to the City of Richland within 90 days of completion of the event or project AND must be expended within the calendar year in which they are granted.
5. I understand that grant progress will be monitored for compliance with scope and timeline.
6. If my event or project is on City-owned property, I have discussed this project with City staff and provided their name above.

***40. By typing my full name below, I agree to the above grant funding requirements, that I am authorized by my agency to submit this application and that all information provided herein is true and correct.**

Trevor Kilgannon

City of Richland - 625 Swift Blvd, MS 39 - Richland, WA 99352
www.ci.richland.wa.us/LodgingTax

Explain how this project meets the above guidelines and criteria for Hotel/Motel Tax Funding

The Hanford Howl is held (practically) in the shoulder season and books a large number of room nights. The Hanford Howl is held in late October every year, practically within the definition of shoulder season. Our event has been long standing and is a keynote tournament for those that participate every year. We work very closely with the Holiday Inn Richland on the River as we book out their entire hotel for Saturday night (and most of the hotel for Friday night) so that our event can maintain a sense of community while still being a relatively large event. Every year since 2013 (pandemic years excluded) we have hosted this tournament and booked over 280 room nights at this hotel.

The Hanford Howl supports local non-profit organizations. The Hanford Howl is an event hosted by Three Rivers Ultimate (TRU), the local organizing body for Ultimate Frisbee in the Tri-Cities area. TRU is 501c3 a non-profit organization, with all money being spent back on the community through increased field rentals, community events, or growing the sport locally. This event provides \$4,000 to TRU to fund annual activities. The Hanford Howl has also historically supported Special Olympics WA through donation of a large portion of the revenue from the tournament. Our 2022 event donated \$10,000 to Special Olympics. We are very proud of this relationship strive to maintain it into the future. The tournament also donates to the chosen charity of choice for the bracket winners of our tournament, in 2022 this totaled \$1,500. In total, \$15,500 was donated to non-profit organizations in 2022.

The Hanford Howl had a wide economic impact on the large Tri-Cities area. The Hanford Howl brings many people to town from outside the Tri-Cities area for a weekend in late October. In addition to the hotel bookings at Holiday Inn Richland on the River, all of these participants eat and socialize in the Tri-Cities for several of days. After our 2022 event, we had Visit Tri-Cities perform an Economic Impact Analysis based on our event numbers. Based on their Impact Generator, the "2022 Hanford Howl had a total economic impact of \$216,064.00."



LODGING TAX ADVISORY COMMITTEE AGENDA ITEM ITEM COVERSHEET

Meeting Date: 10/14/2024

Agenda Category: Hotel/Motel Grant Applications

Prepared By: Trevor Kilgannon

Subject:

Three Rivers Ultimate - 2025 Heat Up Ultimate Frisbee Tournament

Department:

City Manager

Recommended Motion:

Summary:

Three Rivers Ultimate and HeatWave Ultimate are requesting funding for a two-day event that will take place on June 7th and 8th, 2025. Three Rivers Ultimate is requesting \$1,500 with an operating expense of about \$5,000.

Fiscal Impact:

Three Rivers Ultimate is requesting \$1,500.

Attachments:

- I. Three Rivers Ultimate - 2025 Heat Up Ultimate Frisbee Tournament

Submission # 3481737
IP Address 35.132.156.248
Submission Recorded On 09/12/2024 9:03 PM
Time to Take Survey 27 minutes, 58 seconds

Page 1 - Applicant Information



2025 Lodging Tax Grant Application

Please review the [LTAC Program Information](#) prior to beginning the application process.

Preview the application questions before you begin. The application is a one-time process; you cannot pause, save, or restart once you begin.

APPLICANT INFORMATION

* **1. Name of Organization** ?

Three Rivers Ultimate

* **2. Business or Agency Type**

Non-Profit

* **3. Attach Completed W-9 Form** ?

TRUw9.pdf

* **4. Non-Profit Agencies - Attach Proof** ?

IRS_TRU_Nonprofit_determination.pdf

* **5. Applicant Name** ?

Trevor Kilgannon

* **6. Applicant Title or Organizational Role**

Executive Director

* **7. Full Address**

PO BOX 1232
Richland WA 99352

* **8. Applicant Phone Number** ?

(206) 618-7403

* **9. Applicant Email Address** ?

threeriversultimate@gmail.com

Page 2 - Grant Details

GRANT DETAILS

* **10. Dollar Amount of Grant Funding Requested** ?

1,500.00

* **11. Grant Use Type** ?

Event

* **12. For events or projects on City-owned property, please provide the name of the City employee you have reviewed this application with.** ?

SKIPPED

* **13. Title of the Proposed Event or Project** ?

2025 Heat Up Ultimate Frisbee Tournament

* **14. Event or Project Description (will be used in the contract language if granted)** ?

Dear City of Richland, We are excited to present "Heat Up," the first-ever USAU sanctioned Ultimate Frisbee tournament to be held in Richland, Washington. Organized by Three Rivers Ultimate and HeatWave Ultimate, this two-day event will take place on June 7th and 8th, 2025, and promises to bring an energetic and competitive atmosphere to the city.

Non-Grant Funding Sources and Amounts

* **15. Tourism Marketing - Name of Funding Source** ?

SKIPPED

* **16. Tourism Marketing - Dollar Amount** ?

SKIPPED

* **17. Event/Festival Marketing - Name of Funding Source** ?

SKIPPED

18. Event/Festival Marketing - Dollar Amount ?

SKIPPED

19. Tourism Facility Operation - Name of Funding Source ?

Sanctioning fees, field rentals, Medical trainer

20. Tourism Facility Operation - Dollar Amount ?

5,000.00

*** 21. TOTAL NON-GRANT FUNDING BUDGET - Dollar Amount** ?

5,000.00

Grant Funding Requested - Planned Amounts and Distribution

22. Event/Festival Marketing - Dollar Amount ?

SKIPPED

23. Tourism Marketing - Dollar Amount ?

SKIPPED

24. Tourism Facility Operation - Dollar Amount ?

1,500.00

*** 25. TOTAL OF GRANT FUNDS - Dollar Amount** ?

1,500.00

Page 3 - Attendance Estimates

ATTENDANCE ESTIMATES

The State of Washington **requires** attendance estimates, here are the accepted methods of calculation:

Direct Count: Actual count of visitors using methods such as paid admissions or registrations, clicker counts at entry points, vehicle counts or number of chairs filled. A direct count may also include information collected directly from businesses, such as hotels, restaurants or tour guides, likely to be affected by an event.

Indirect Count: Estimate based on information related to the number of visitors such as raffle tickets sold, redeemed discount certificates, brochures handed out, police requirements for crowd control or visual estimates.

Representative Survey: Information collected directly from individual visitors/participants. A representative survey is a highly structured data collection tool, based on a defined random sample of participants, and the results can be reliably projected to the entire population attending an event and includes margin of error and confidence level.

Informal Survey: Information collected directly from individual visitors or participants in a non-random manner that is not representative of all visitors or participants. Informal survey results cannot be projected to the entire visitor population and provide a limited indicator of attendance because not all participants had an equal chance of being included in the survey.

Structured Estimate: Estimate produced by computing known information related to the event or location. For example, one jurisdiction estimated attendance by dividing the square footage of the event area by the international building code allowance for persons (3 square feet).

*** 26. Predicted Overall Attendance - Estimation Method Used** ?

Structured Estimate

*** 27. Predicted Overall Attendance - Estimated Number** ?

200

*** 28. Predicted Attendance, 50+ Miles - Estimation Method Used** ?

Structured Estimate

*** 29. Predicted Attendance, 50+ Miles - Estimated Number** ?

175

*** 30. Predicted Attendance, Out of State, Out of Country - Estimation Method Used** ?

Structured Estimate

*** 31. Predicted Attendance, Out of State, Out of Country - Estimated Number** ?

50

*** 32. Predicted Attendance, Paid for Overnight Lodging - Estimation Method Used** ?

Structured Estimate

*** 33. Predicted Attendance, Paid for Overnight Lodging - Estimated Number** ?

175

*** 34. Predicted Attendance, Did Not Pay for Overnight Lodging - Estimation Method Used** ?

Structured Estimate

*** 35. Predicted Attendance, Did Not Pay for Overnight Lodging - Estimated Number** ?

25

36. Predicted Paid Lodging Nights - Estimation Method Used ?

Structured Estimate

*** 37. Predicted Paid Lodging Nights - Estimated Number** ?

50

Page 4 - Conditions for Grant Approval

CONDITIONS FOR GRANT APPROVAL

38. Supplemental #1 ?

Heat Up Ultimate Frisbee Tournament.pdf

39. Supplement #2 ?

****SKIPPED****

I acknowledge and agree to the below grant funding criteria:

1. I may be required to make a presentation to the advisory committee about my event/project.
2. All advertising will include the (provided) City of Richland logo and/or the phrase "Funding provided by City of Richland Lodging Tax Grant program."
3. I agree to submit marketing materials for approval by the Communications & Marketing Manager (or their designee) prior to publishing.
4. A final project report, including reporting requirements meeting state guidelines outlined in the LTAC Program Information document, and all supporting documents will be submitted to the City of Richland within 90 days of completion of the event or project AND must be expended within the calendar year in which they are granted.
5. I understand that grant progress will be monitored for compliance with scope and timeline.
6. If my event or project is on City-owned property, I have discussed this project with City staff and provided their name above.

*

40. By typing my full name below, I agree to the above grant funding requirements, that I am authorized by my agency to submit this application and that all information provided herein is true and correct. ?

Trevor Kilgannon

City of Richland - 625 Swift Blvd, MS 39 - Richland, WA 99352
www.ci.richland.wa.us/LodgingTax

City of Richland Event Support Request

Event Name: Heat Up Ultimate Frisbee Tournament

Event Date: June 7th & 8th, 2025

Event Organizer: Three Rivers Ultimate and HeatWave Ultimate

Dear City of Richland,

We are excited to present "Heat Up," the first-ever USAU sanctioned Ultimate Frisbee tournament to be held in Richland, Washington. Organized by Three Rivers Ultimate and HeatWave Ultimate, this two-day event will take place on June 7th and 8th, 2025, and promises to bring an energetic and competitive atmosphere to the city.

Event Details:

- **Teams:** We are expecting 7 out-of-town teams to participate, bringing approximately 140 athletes and staff from various regions.
- **Venue:** The tournament will be held at rented fields within Richland.
- **Economic Impact:** With teams traveling from outside of the area, we anticipate a boost in local spending on accommodations, dining, and other services, contributing positively to the city's economy. The event will showcase Richland as a destination for sports tourism, bringing new visitors to the community.

Estimated Costs: To run a successful event, we expect to incur approximately \$3,000 in costs. These include:

- **Sanctioning fees:** Official dues to USA Ultimate to host a sanctioned event.
- **Field Rentals:** Usage of local fields to accommodate the teams and games.
- **Trainer/Medical Staff:** Ensuring player safety with an on-site trainer.
- **Other Operational Costs:** Including equipment, snacks, and promotional materials.

Request for Support: We are requesting support from the City of Richland's event funding program to help cover a portion of the operational expenses. Your contribution would greatly assist in making the event a success, attracting new visitors to Richland, and building a foundation for the tournament to become an annual event.

We believe that "Heat Up" will bring lasting benefits to the city by highlighting Richland as a hub for competitive sports, strengthening community ties, and fostering economic activity. We look forward to the possibility of partnering with the City of Richland to make this event a landmark success.

To clarify, this event is not a replacement for the annual Hanford Howl which occurs near Halloween weekend. We are submitting this request as an addition to that request. However, if each organization is only permitted one opportunity per year we would appreciate you prioritizing the larger Hanford Howl event over Heat Up.

Thank you for your consideration of this request. We are happy to provide any further information or documentation you may need.

Sincerely,
Trevor Kilgannon
Three Rivers Ultimate



LODGING TAX ADVISORY COMMITTEE AGENDA ITEM ITEM COVERSHEET

Meeting Date: 10/14/2024

Agenda Category: Hotel/Motel Grant Applications

Prepared By: Patrick Barrett

Subject:

Babe Ruth - Baseball Infield Renovation

Department:

City Manager

Recommended Motion:

Summary:

Richland Babe Ruth Baseball Association is requesting \$348,000 for an infield renovation by installing field turf and portable mounds on all 4 baseball fields.

Fiscal Impact:

Richland Babe Ruth Baseball Association is requesting \$384,000.

Attachments:

I. Babe Ruth - Baseball Infield Renovation



2025 Lodging Tax Grant Application

Please review the [LTAC Program Information](#) prior to beginning the application process.

Preview the application questions before you begin. The application is a one-time process; you cannot pause, save, or restart once you begin.

APPLICANT INFORMATION

***1. Name of Organization**
Richland Babe Ruth Baseball Association

*2. Business or Agency Type
Non-Profit

*3. Attach Completed W-9 Form
2024 baberuth-w-9-signed.pdf

4. Non-Profit Agencies - Attach Proof
babe-ruth-nonprofit-certificate.pdf

*5. Applicant Name
President Patrick Barrett

6. Applicant Title or Organizational Role
League President

*7. Full Address
2705 Kingsgate Way
Richland wa 99352

*8. Applicant Phone Number
(509) 727-4863

*9. Applicant Email Address
pkbarrett@charter.net

GRANT DETAILS

***10. Dollar Amount of Grant Funding Requested**
384,000.00

*11. Grant Use Type
Project: on City-owned Property or Facility

12. For events or projects on City-owned property, please provide the name of the City employee you have reviewed this application with.
Shawn Harper, Christopher Waite

*13. Title of the Proposed Event or Project
Baseball Infield renovation

*14. Event or Project Description (will be used in the contract language if granted)
Installing field turf and portable mounds on all 4 baseball fields.

Non-Grant Funding Sources and Amounts

15. Tourism Marketing - Name of Funding Source
N/A

16. Tourism Marketing - Dollar Amount

SKIPPED

17. Event/Festival Marketing - Name of Funding Source
n/a

18. Event/Festival Marketing - Dollar Amount
SKIPPED

19. Tourism Facility Operation - Name of Funding Source
n/a

20. Tourism Facility Operation - Dollar Amount
SKIPPED

***21. TOTAL NON-GRANT FUNDING BUDGET - Dollar Amount**
SKIPPED

Grant Funding Requested - Planned Amounts and Distribution

22. Event/Festival Marketing - Dollar Amount
SKIPPED

23. Tourism Marketing - Dollar Amount
SKIPPED

24. Tourism Facility Operation - Dollar Amount
SKIPPED

***25. TOTAL OF GRANT FUNDS - Dollar Amount**
SKIPPED

ATTENDANCE ESTIMATES

The State of Washington **requires** attendance estimates, here are the accepted methods of calculation:

Direct Count: Actual count of visitors using methods such as paid admissions or registrations, clicker counts at entry points, vehicle counts or number of chairs filled. A direct count may also include information collected directly from businesses, such as hotels, restaurants or tour guides, likely to be affected by an event.

Indirect Count: Estimate based on information related to the number of visitors such as raffle tickets sold, redeemed discount certificates, brochures handed out, police requirements for crowd control or visual estimates.

Representative Survey: Information collected directly from individual visitors/participants. A representative survey is a highly structured data collection tool, based on a defined random sample of participants, and the results can be reliably projected to the entire population attending an event and includes margin of error and confidence level.

Informal Survey: Information collected directly from individual visitors or participants in a non-random manner that is not representative of all visitors or participants. Informal survey results cannot be projected to the entire visitor population and provide a limited indicator of attendance because not all participants had an equal chance of being included in the survey.

Structured Estimate: Estimate produced by computing known information related to the event or location. For example, one jurisdiction estimated attendance by dividing the square footage of the event area by the international building code allowance for persons (3 square feet).

***26. Predicted Overall Attendance - Estimation Method Used**

Structured Estimate

***27. Predicted Overall Attendance - Estimated Number**

5,700

***28. Predicted Attendance, 50+ Miles - Estimation Method Used**

Informal Survey

***29. Predicted Attendance, 50+ Miles - Estimated Number**

2,300

***30. Predicted Attendance, Out of State, Out of Country - Estimation Method Used**

Informal Survey

***31. Predicted Attendance, Out of State, Out of Country - Estimated Number**

100

***32. Predicted Attendance, Paid for Overnight Lodging - Estimation Method Used**

Representative Survey

***33. Predicted Attendance, Paid for Overnight Lodging - Estimated Number**

920

***34. Predicted Attendance, Did Not Pay for Overnight Lodging - Estimation Method Used**

Structured Estimate

***35. Predicted Attendance, Did Not Pay for Overnight Lodging - Estimated Number**

3,900

36. Predicted Paid Lodging Nights - Estimation Method Used

Structured Estimate

***37. Predicted Paid Lodging Nights - Estimated Number**

500

CONDITIONS FOR GRANT APPROVAL

- 38. Supplemental #1
Richland Babe Ruth Baseball Association 4 Fields V1 Roll Layout 4.12.24.pdf
- 39. Supplement #2
Project-Evaluation-Application-filled.pdf

I acknowledge and agree to the below grant funding criteria:

1. I may be required to make a presentation to the advisory committee about my event/project.
2. All advertising will include the (provided) City of Richland logo and/or the phrase "Funding provided by City of Richland Lodging Tax Grant program."
3. I agree to submit marketing materials for approval by the Communications & Marketing Manager (or their designee) prior to publishing.
4. A final project report, including reporting requirements meeting state guidelines outlined in the LTAC Program Information document, and all supporting documents will be submitted to the City of Richland within 90 days of completion of the event or project AND must be expended within the calendar year in which they are granted.
5. I understand that grant progress will be monitored for compliance with scope and timeline.
6. If my event or project is on City-owned property, I have discussed this project with City staff and provided their name above.

***40. By typing my full name below, I agree to the above grant funding requirements, that I am authorized by my agency to submit this application and that all information provided herein is true and correct.**

Patrick K Barrett

City of Richland - 625 Swift Blvd, MS 39 - Richland, WA 99352
www.ci.richland.wa.us/LodgingTax

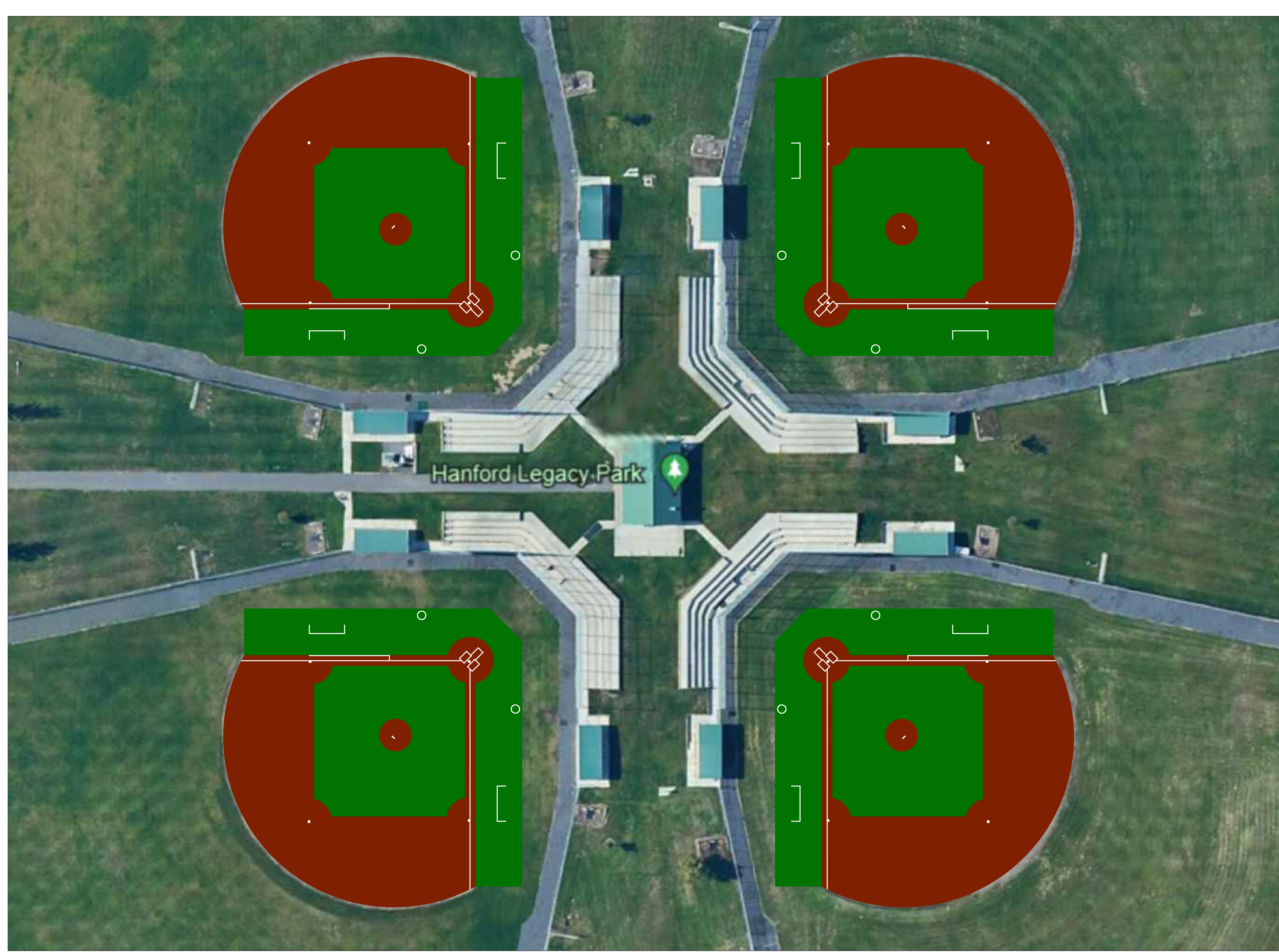

Richland Babe Ruth
Baseball Association 4 Fields

et
ENGINEERED
TURF

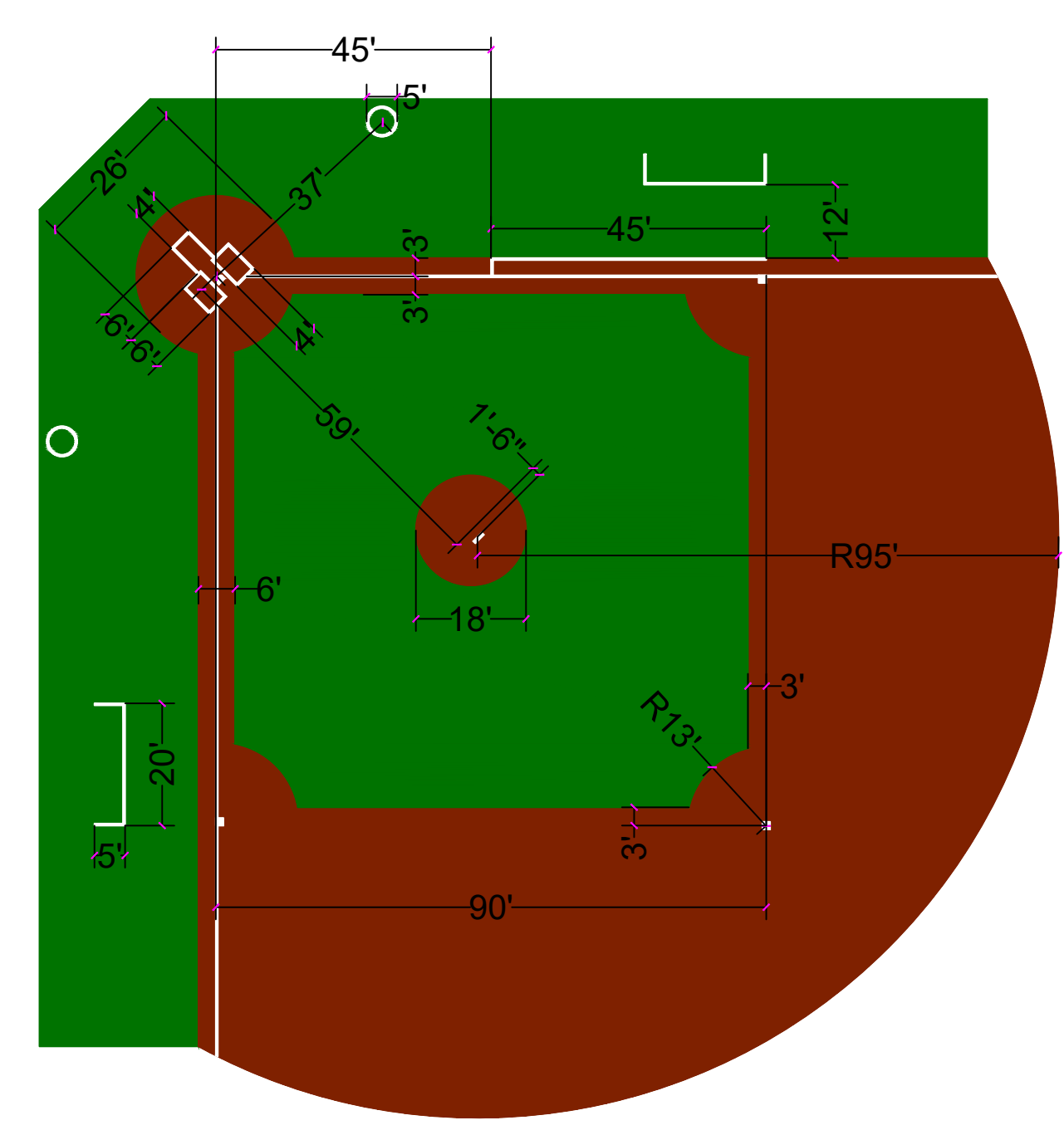
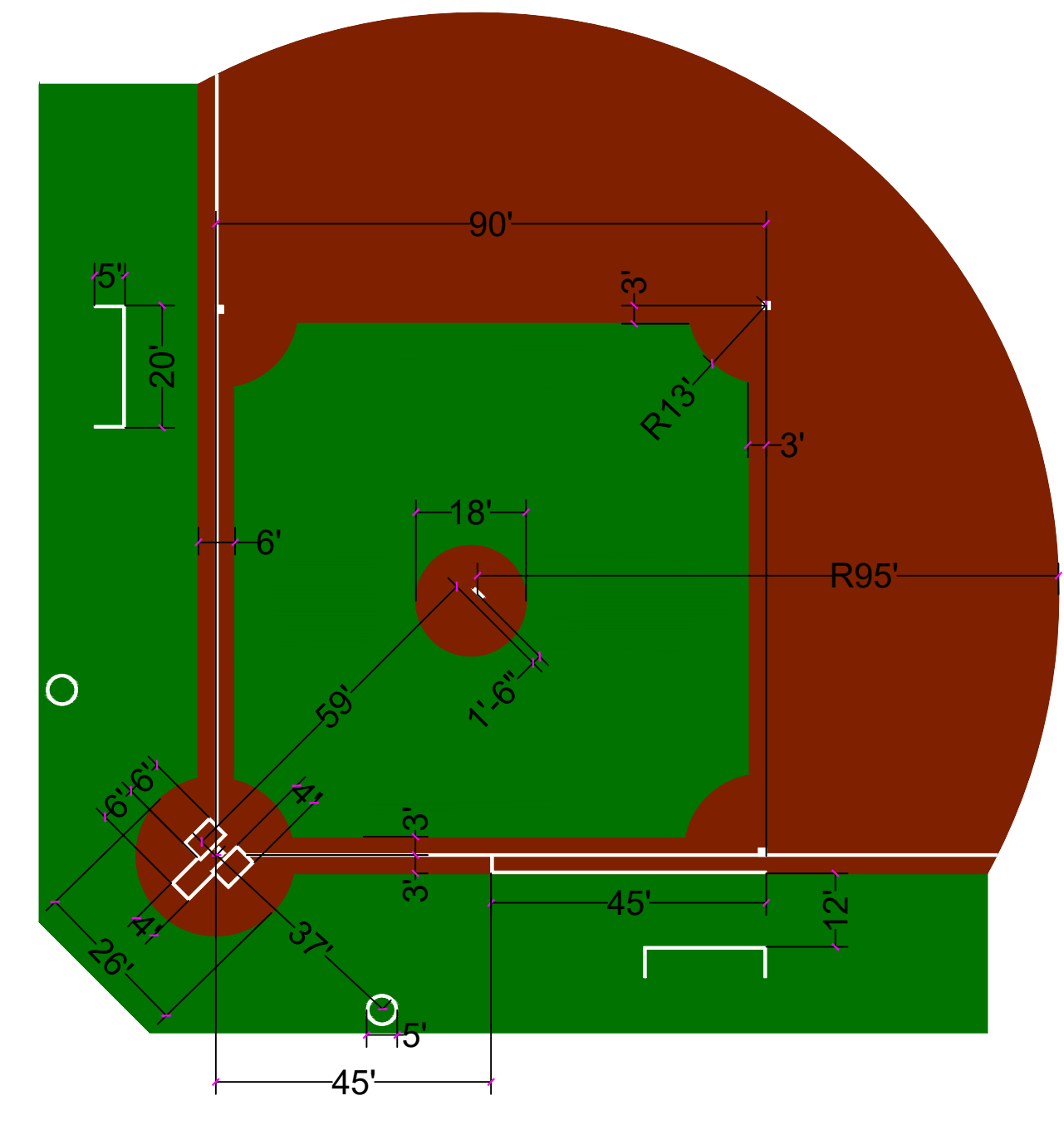
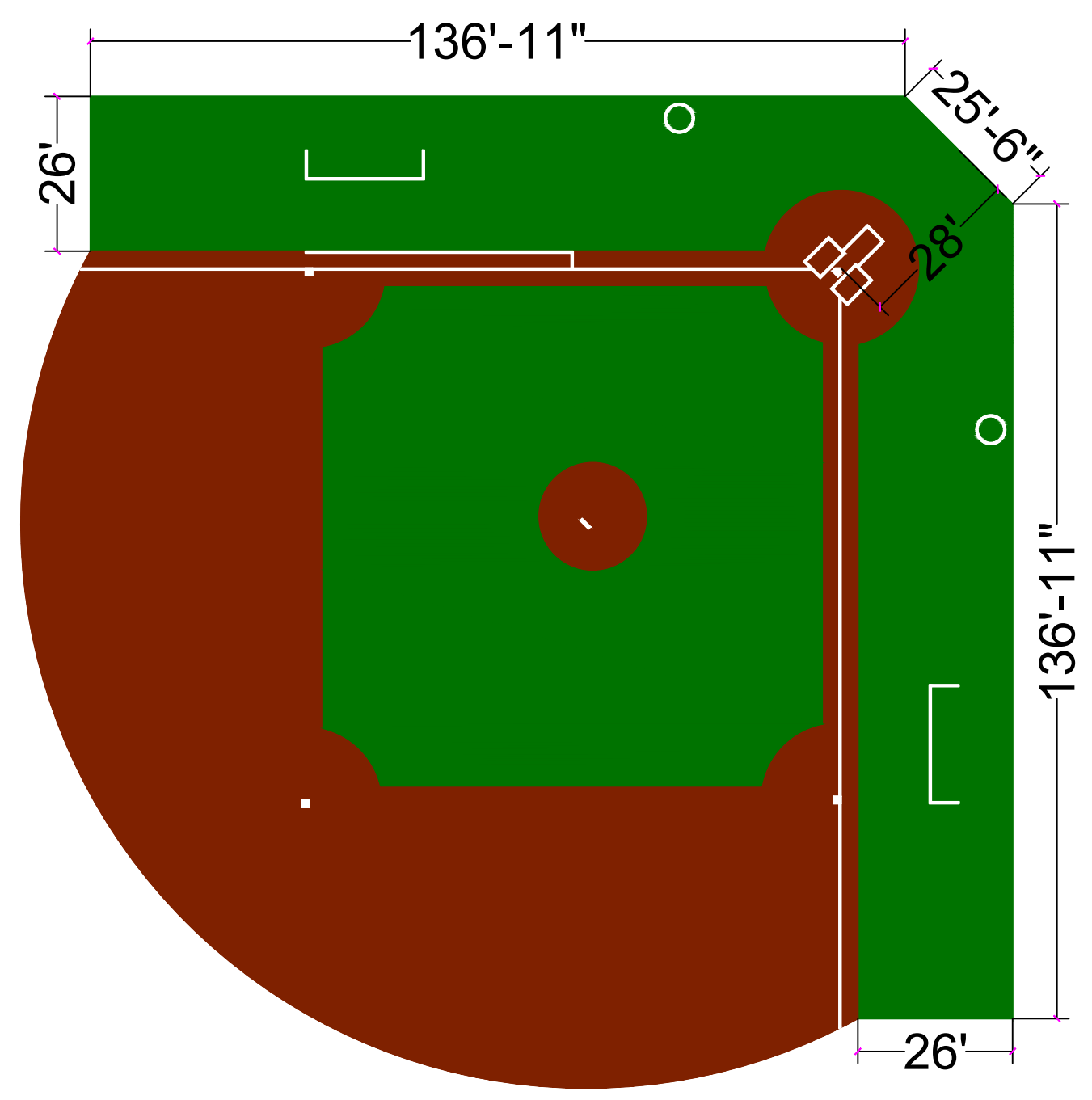
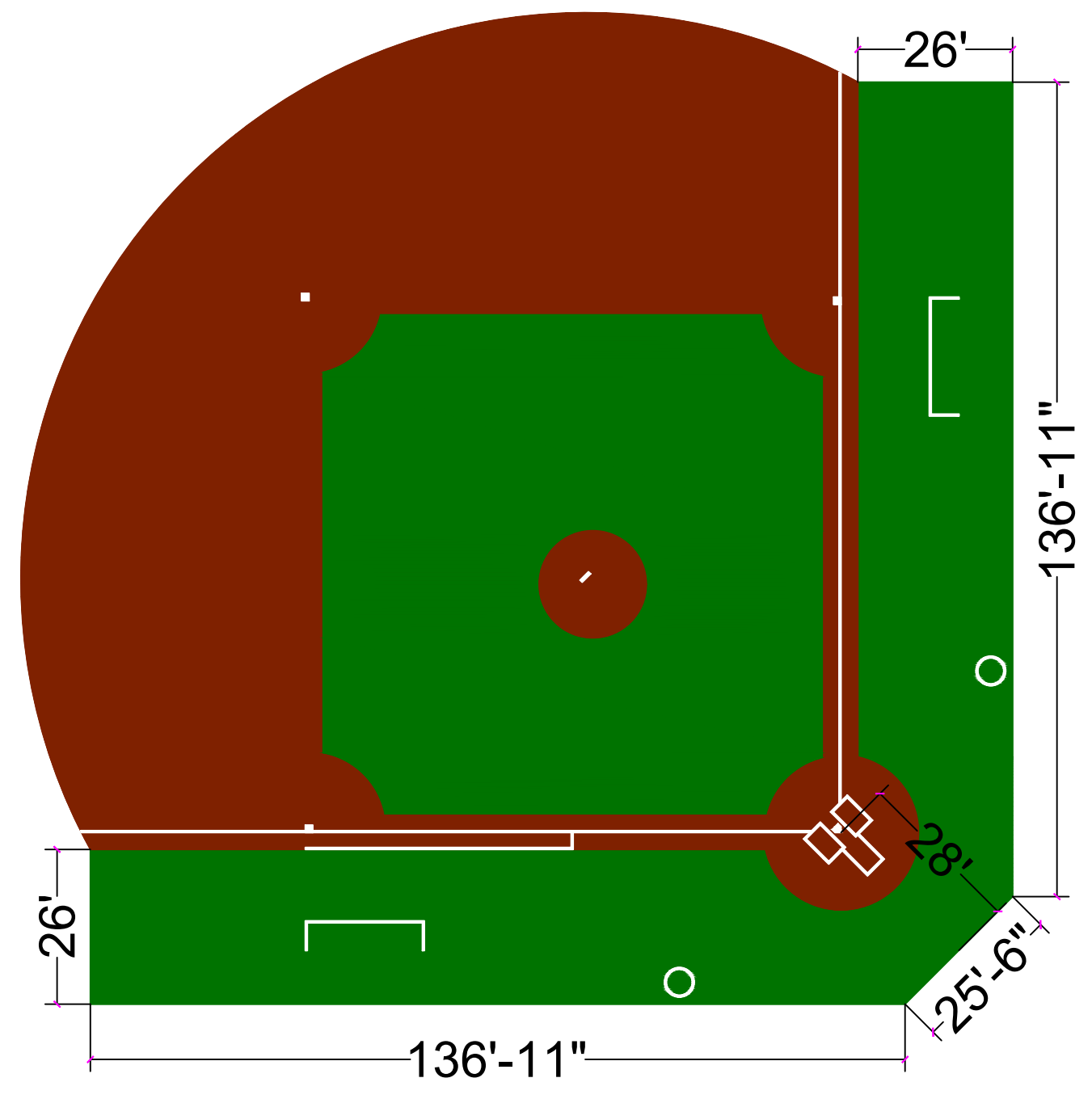

ENGINEERED
TURF

PRODUCT:	REVISIONS:	DATE	BY
	V-1 Roll Layout	4/12/24	CJP

Richland Babe Ruth
Baseball Association 4 Fields

FIELD DIMENSIONS

S1
SHEET #1
OF #5

BY SIGNING THIS FORM YOU AGREE WITH THE PRODUCTION WITH NO CHANGES. CHANGES MUST BE RESUBMITTED FOR FINAL PROOFING. BY SIGNING YOU ARE STATING THAT "I HAVE CHECKED & APPROVE THAT ALL LOGOS, DIMENSIONS, SPELLING & COLORS ARE CORRECT."

PLEASE SIGN WITHIN THIS BOX

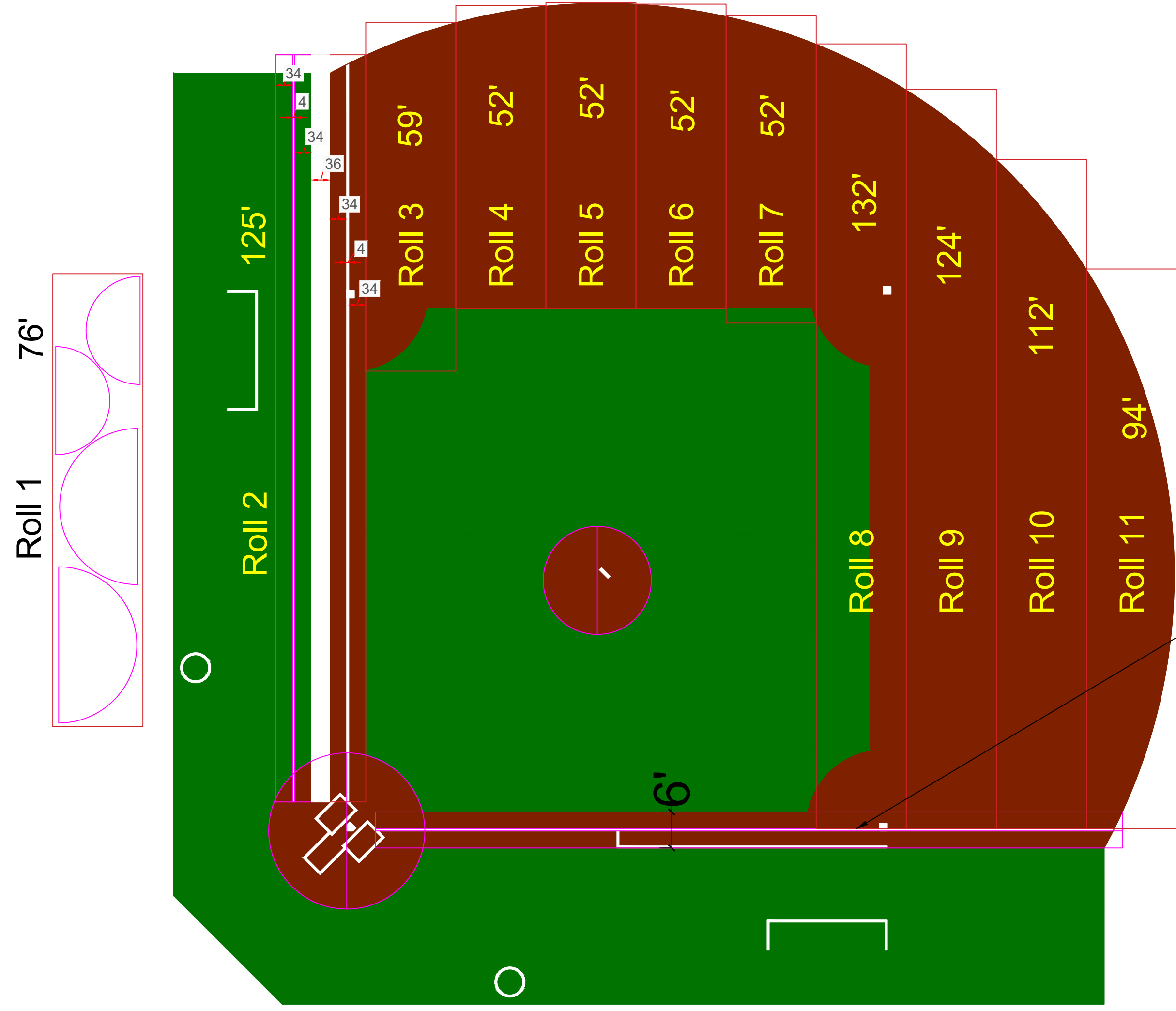

NOTE
Remove top portion of nonwhite material of 6 ft wide base path where rolls meet so all rolls are seamed along the Foul Line. Seam **MUST** be made at the Foul Line.

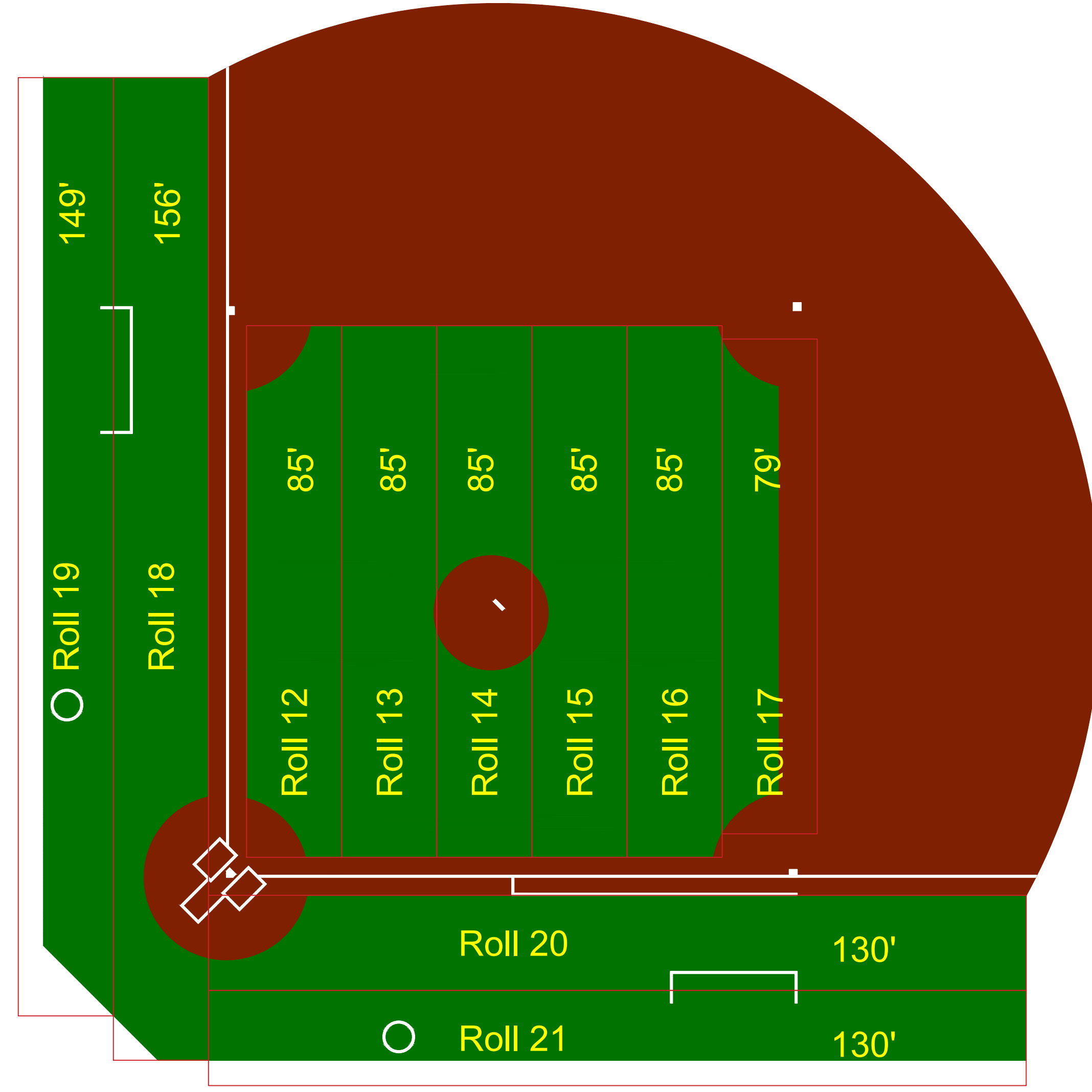

PRODUCT:	DATE	BY
REVISIONS:	4/12/24	CJP
V-1 Roll Layout		

Richland Babe Ruth
Baseball Association 4 Fields

ROLL LAYOUT

The Community Sports Development Council Sports Field Alliance

A NATIONAL NETWORK OF SPONSORS AND FUNDING PARTNERS
SUPPORTING THE INSTALLATION OF NEW ALL WEATHER SPORTS FIELDS

SPORTS FIELD SPONSORSHIP PROJECT EVALUATION FORM- 2022 INITIATIVE

Name of your Organization, School or Agency: Richland Babe Ruth Baseball Association

Full Address: 1405 Hazelwood Ave. Richland, Wa. 99352 Phone: 509-727-4863

Contact Person: Pat Barrett Title: Director

Are you a nonprofit organization? (not required) yes Email: pkbarrett@charter.net

Brief Description of Project under Consideration: 4 Field youth baseball complex 90 ft fields.
We are wanting to get the infields areas turfed.

Size of Field?: 76,000-100,000 (sq. feet) Location of field: 2705 Kingsgate Way

Richland, Wa 99352. Hanford Legacy Park

It is recommended that you attach a separate brief 1 page description (on your organizations letterhead), and please address the following issues- a one or two sentence answer is totally fine:

1. Please describe the specific details/dimensions of your project being considered. Size? Etc.
2. Will the project be located on private or public land? Is the land already acquired?
3. What timeframe is your goal for development or installation?
4. Most of the CSD Alliance sponsored & approved projects will sponsor 60% - 70% of the funding needed. Can your organization provide the balance (Typically \$ 380,000 - 440,000 for a full size 80,000 sq. ft.) of the funds needed?

Please email this document, feel free to add a cover letter for processing with the CSD Alliance review committee. Applications are reviewed as they are received, typically requiring a 14 day review period. If your application meets the general guidelines for approval you will be so notified and you may be requested to submitting additional supporting information through our CSDA representative.

Scan & Email to: info@csdcouncil.org
Attention: Project Evaluation Committee

Mailing Address: **CSD Alliance- Sports Field Alliance**
4676 Commercial SE #1
Salem, Oregon 97302

Thank you !!

The Sports Field Alliance Sponsorship Team

THANK YOU TO OUR CORPORATE
PARTNERS & SUPPORTIVE VENDORS



GENERAL ELECTRIC
GE POLYMERS (PAVILIONS)
TURF MILL DIRECT
WESTERN RUBBER
DELTA GRIND RUBBER
LIBERTY RECYCLING
NUCOR STEEL SYSTEMS
BAEZ SPORTS GROUP
BISSETTE ARCHITECTURE
LOWES.COM
HOME DEPOT.COM
BUSINESS LIGHTS.COM
OLYMPIA STEEL
FARWEST STEEL
SPORTS LIFE INTERNATIONAL
SPORTS ACROSS IRELAND
BALLYMUNN REGENERATION,
LTD.

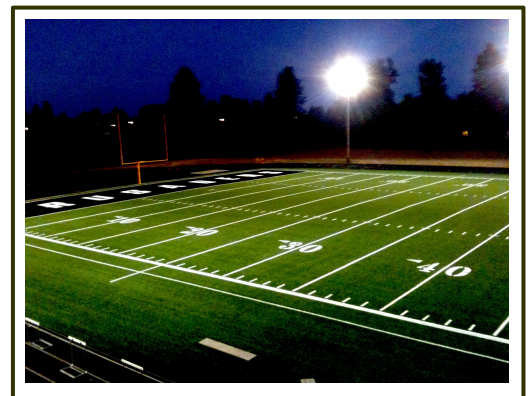

OFFICES & REPRESENTATIVES IN: CALIFORNIA. * OREGON * TULSA, OKLAHOMA
www.csdcouncil.org Phone: 503.581.1838 Email: info@csdcouncil.org



LODGING TAX ADVISORY COMMITTEE AGENDA ITEM ITEM COVERSHEET

Meeting Date: 10/14/2024

Agenda Category: Hotel/Motel Grant Applications

Prepared By: Sam McPeck

Subject:

Mid-Columbia BMX - Starting Hill Improvement Phase I - Gate Replacement

Department:

City Manager

Recommended Motion:

Summary:

Mid-Columbia BMX is requesting funding to replace the BMX Starting Gate, as well as the concrete and asphalt approach and hill below the gate itself. Mid-Columbia BMX is requesting \$85,250.

Fiscal Impact:

Mid-Columbia BMX is requesting \$82,250.

Attachments:

- I. Mid-Columbia BMX - Starting Hill Improvement Phase I - Gate Replacement

Submission # 3498423
IP Address 68.119.2.236
Submission Recorded On 09/20/2024 3:44 PM
Time to Take Survey 28 minutes, 16 seconds

Page 1 - Applicant Information



2025 Lodging Tax Grant Application

Please review the [LTAC Program Information](#) prior to beginning the application process.

Preview the application questions before you begin. The application is a one-time process; you cannot pause, save, or restart once you begin.

APPLICANT INFORMATION

*** 1. Name of Organization ?**

Mid-Columbia BMX

*** 2. Business or Agency Type**

Non-Profit

*** 3. Attach Completed W-9 Form ?**

W-9.jpg

4. Non-Profit Agencies - Attach Proof ?

Non Profit Status.pdf

*** 5. Applicant Name ?**

Sam McPeek

6. Applicant Title or Organizational Role

Track Operator - Governor

*** 7. Full Address**

1210 ROBERDEAU ST.
RICHLAND WA 99354

*** 8. Applicant Phone Number ?**

(509) 308-6944

*** 9. Applicant Email Address ?**

midcbmx@gmail.com

Page 2 - Grant Details

GRANT DETAILS

*** 10. Dollar Amount of Grant Funding Requested ?**

85,250.00

*** 11. Grant Use Type ?**

Project: on City-owned Property or Facility

12. For events or projects on City-owned property, please provide the name of the City employee you have reviewed this application with. ?

Stacy Jackson

*** 13. Title of the Proposed Event or Project ?**

Starting Hill Improvement Phase 1 - Gate Replacement

*** 14. Event or Project Description (will be used in the contract language if granted) ?**

This application is for the replacement of the BMX Starting Gate, as well as the concrete and asphalt approach and hill below the gate itself. The driver for this is the current gate was installed in 2013, and was used at the time. It is at the end of its lifespan, takes a lot of maintenance to keep it running and new technology enhances safety for riders. This installation will also make future maintenance and replacement easier as it will be built to industry standards.

Non-Grant Funding Sources and Amounts

15. Tourism Marketing - Name of Funding Source ?

N/A

16. Tourism Marketing - Dollar Amount ?

SKIPPED

17. Event/Festival Marketing - Name of Funding Source ?

N/A

18. Event/Festival Marketing - Dollar Amount ?

SKIPPED

19. Tourism Facility Operation - Name of Funding Source ?

N/A

20. Tourism Facility Operation - Dollar Amount ?

SKIPPED

* 21. TOTAL NON-GRANT FUNDING BUDGET - Dollar Amount ?

SKIPPED

Grant Funding Requested - Planned Amounts and Distribution

22. Event/Festival Marketing - Dollar Amount ?

SKIPPED

23. Tourism Marketing - Dollar Amount ?

SKIPPED

24. Tourism Facility Operation - Dollar Amount ?

85,250.00

* 25. TOTAL OF GRANT FUNDS - Dollar Amount ?

85,250.00

ATTENDANCE ESTIMATES

The State of Washington **requires** attendance estimates, here are the accepted methods of calculation:

Direct Count: Actual count of visitors using methods such as paid admissions or registrations, clicker counts at entry points, vehicle counts or number of chairs filled. A direct count may also include information collected directly from businesses, such as hotels, restaurants or tour guides, likely to be affected by an event.

Indirect Count: Estimate based on information related to the number of visitors such as raffle tickets sold, redeemed discount certificates, brochures handed out, police requirements for crowd control or visual estimates.

Representative Survey: Information collected directly from individual visitors/participants. A representative survey is a highly structured data collection tool, based on a defined random sample of participants, and the results can be reliably projected to the entire population attending an event and includes margin of error and confidence level.

Informal Survey: Information collected directly from individual visitors or participants in a non-random manner that is not representative of all visitors or participants. Informal survey results cannot be projected to the entire visitor population and provide a limited indicator of attendance because not all participants had an equal chance of being included in the survey.

Structured Estimate: Estimate produced by computing known information related to the event or location. For example, one jurisdiction estimated attendance by dividing the square footage of the event area by the international building code allowance for persons (3 square feet).

* 26. Predicted Overall Attendance - Estimation Method Used ?

Structured Estimate

* 27. Predicted Overall Attendance - Estimated Number ?

10,000

* 28. Predicted Attendance, 50+ Miles - Estimation Method Used ?

Structured Estimate

* 29. Predicted Attendance, 50+ Miles - Estimated Number ?

9,500

* 30. Predicted Attendance, Out of State, Out of Country - Estimation Method Used ?

Structured Estimate

* 31. Predicted Attendance, Out of State, Out of Country - Estimated Number ?

9,000

* 32. Predicted Attendance, Paid for Overnight Lodging - Estimation Method Used ?

Structured Estimate

* 33. Predicted Attendance, Paid for Overnight Lodging - Estimated Number ?

8,000

* 34. Predicted Attendance, Did Not Pay for Overnight Lodging - Estimation Method Used ?

Structured Estimate

* 35. Predicted Attendance, Did Not Pay for Overnight Lodging - Estimated Number ?

1,000

36. Predicted Paid Lodging Nights - Estimation Method Used ?

Structured Estimate

*** 37. Predicted Paid Lodging Nights - Estimated Number** ?

300

Page 4 - Conditions for Grant Approval

CONDITIONS FOR GRANT APPROVAL

38. Supplemental #1 ?

Gate Project Bid Estimates.pdf

39. Supplement #2 ?

Gate Project Pictures.pdf

I acknowledge and agree to the below grant funding criteria:

1. I may be required to make a presentation to the advisory committee about my event/project.
2. All advertising will include the (provided) City of Richland logo and/or the phrase "Funding provided by City of Richland Lodging Tax Grant program."
3. I agree to submit marketing materials for approval by the Communications & Marketing Manager (or their designee) prior to publishing.
4. A final project report, including reporting requirements meeting state guidelines outlined in the LTAC Program Information document, and all supporting documents will be submitted to the City of Richland within 90 days of completion of the event or project AND must be expended within the calendar year in which they are granted.
5. I understand that grant progress will be monitored for compliance with scope and timeline.
6. If my event or project is on City-owned property, I have discussed this project with City staff and provided their name above.

*

40. By typing my full name below, I agree to the above grant funding requirements, that I am authorized by my agency to submit this application and that all information provided herein is true and correct. ?

Samuel Ouren McPeek

City of Richland - 625 Swift Blvd, MS 39 - Richland, WA 99352
www.ci.richland.wa.us/LodgingTax

PROSTART CORP

554 25 Rd, Suite 5
 Grand Junction, CO 81505 USA
 +19705599438
 america@prostart-bmxgates.com
 www.prostart-bmxgates.com

**Estimate**

ADDRESS	SHIP TO	SHIP VIA	TRUCK LTL FREIGHT	ESTIMATE DATE	1329 09/02/2024
Columbia Basin BMX 2002 Snyder St Richland, WA 99354	Columbia Basin BMX 2002 Snyder St Richland, WA 99354				

ACTIVITY	DESCRIPTION	QTY	RATE	AMOUNT
8-RIDER STRUCTURE SAFETY GATE	15° angle (Different upon request) Galvanized frames (Qty: 10) 2meters aluminium squared tube (Qty: 16) Ram fixation support (Qty: 1) PVC Ram cover (Qty: 1) Side grates 1120x250 (Qty: 4) Set of dowels, BTR screws, locknuts & self drilling screws.	1	3,500.00	3,500.00
8-RIDER ALUMINUM SAFETY GATE	Galvanized angle with axles (Qty : 5) Aluminum quarter-barrel module 1x0.5m, stainless axles (Qty:8) Aluminum grate 1x0.5m (Qty:8) 50mm diameter rubber pad (Qty : 8) Set of dowels, BTR screws, locknuts & self drilling screws	1	8,300.00	8,300.00
8-RIDER BACK & FRONT GRATES (Double way sawtoth)	Back grate 1.5x1m (Qty : 8) Front grate 0.2x1m (Qty : 8) Set of bolts and dowels	1	2,300.00	2,300.00
COMPLETE ELECTRIC RAM 220V for 100% electric gate	(The next level of bmx gates) Electric cylinder ballscrew DN80 C400(Qty : 1) Brushless motor 6000tr/min 220V MOTOR (Qty : 1) This solution needs to be supplied by a EBOX starting system.	1	5,300.00	5,300.00
EBOX - Starting system for 100% electric gate	(The complete system in compliance with UCI/USA BMX/UEC/BMX AUSTRALIA) UCI Random electrical box (Qty:1) Remote 3 buttons water&shock proof (Qty:1) 30W IP62 louspeaker (Qty:1) Connector IP65 Plug & Play with box (Quantity: 3) Driver to control the motor (Qty : 1) Power cable 10 meters (Qty : 1). Data cable 10 meters (Qty : 1) This solution needs 3x200/260V 16A electricity. If you don't have this type of electricity, please let us know to upgrade the quote with a rotary phase converter and/or a step up transformer. If you need longer cables, please contact us in order to send you the adapted quote.	1	3,800.00	3,800.00

POWER ADAPTER FOR ELECTRIC GATE (Shipping included)	Factory based in New Berlin, Winsconsin, USA Input electricity : single phase 200V (30Amp needed) Output electricity : Three phase 20-220V with 20Amp availability All-in-one rotary phase converter from NAPCES	1	1,200.00	1,200.00
PROLIGHT - Set of two starting lights	Starting light 4-lamp LED high luminosity high luminosity (Qty : 2) Connectors EPIC IP65 Plug & Play (Qty : 2) Fixations (Qty : 4)	1	600.00	600.00
First-Aid CASE for 100% ELECTRIC GATES	The most problematic electric parts to always have in your drawer 1x Robust cardbox to keep all the parts in easy access & safe place 1x VoiceCard (green card) adapted to your control box version 1x 24Vdc power supply 2.5A 1x Speaker 30W 1x Complete remote with cable and male connector 1x Complete connector set 1x MP2 Female Clevis STEEL VERSION (Clevis on the ram) 1x MP4 Male Clevis STEEL VERSION (Clevis on the structure) 1x AP6 Ball Joint (On the ram nose) 1x AB6 Female Clevis (Clevis on the gate) 2x Stainless Gate axle hinge for Prostart 100% Electric gates	1	1,000.00	1,000.00
TRANSPORT MAR FACTORY FRANCE TO XXX - DAP - GSx	Complete gate - Boat solution 60 days transport door-to-door Factory in La Rochelle, FRANCE 4.0m3 of volume - 2 palet of 1250x1000x1670 mm (WxDxH in millimeter) Weight 750 kilos DDP (Direct Duty Paid) Duty & taxes included. Transport to BMX Track Richland WA included	1	4,550.00	4,550.00
PLANE TICKET GRAND-JUNCTION, CO <-> XXX, XXX - ECO class	TO Tri-Cities (PSC) airport This price is subject to modifications (Up or down) according to the period and the date of booking before the arrival..	1	800.00	800.00
CAR RENTAL - 5 days - Economic car	Update : 4 DAYS This price is subject to modifications (Up or down) according to the period and the date of booking before the arrival..	1	400.00	400.00
ACCOMODATION COSTS (HOTEL + FOOD)	Single room hotel + food for breakfast, lunch & dinner. By person and by night. (3 nights)		450.00	450.00
MANWORKS AND COMMISSIONING ON SITE - GSE	Mounting of all the metallic parts Passage of electric cables Electric connection(electrical box, lights, cylinder, loudspeaker, stopwatch) Settings and testing	1	3,200.00	3,200.00

Deposit payment of 30% + estimate to sign in order to validate the order.

SUBTOTAL

35,400.00

Second payment of 50% just before the shipment of the pallet.

TAX

0.00

Third and last payment (20%) after installation successful.

Delay : TOTAL 21 weeks
13 weeks to prepare the material
7 weeks transportation by boat to
1 week of installation on site

TOTAL

\$35,400.00

Work on site : 2 days

Accepted By

Accepted Date

H G F E D C B A

4

4

Fibre concrete

3

3

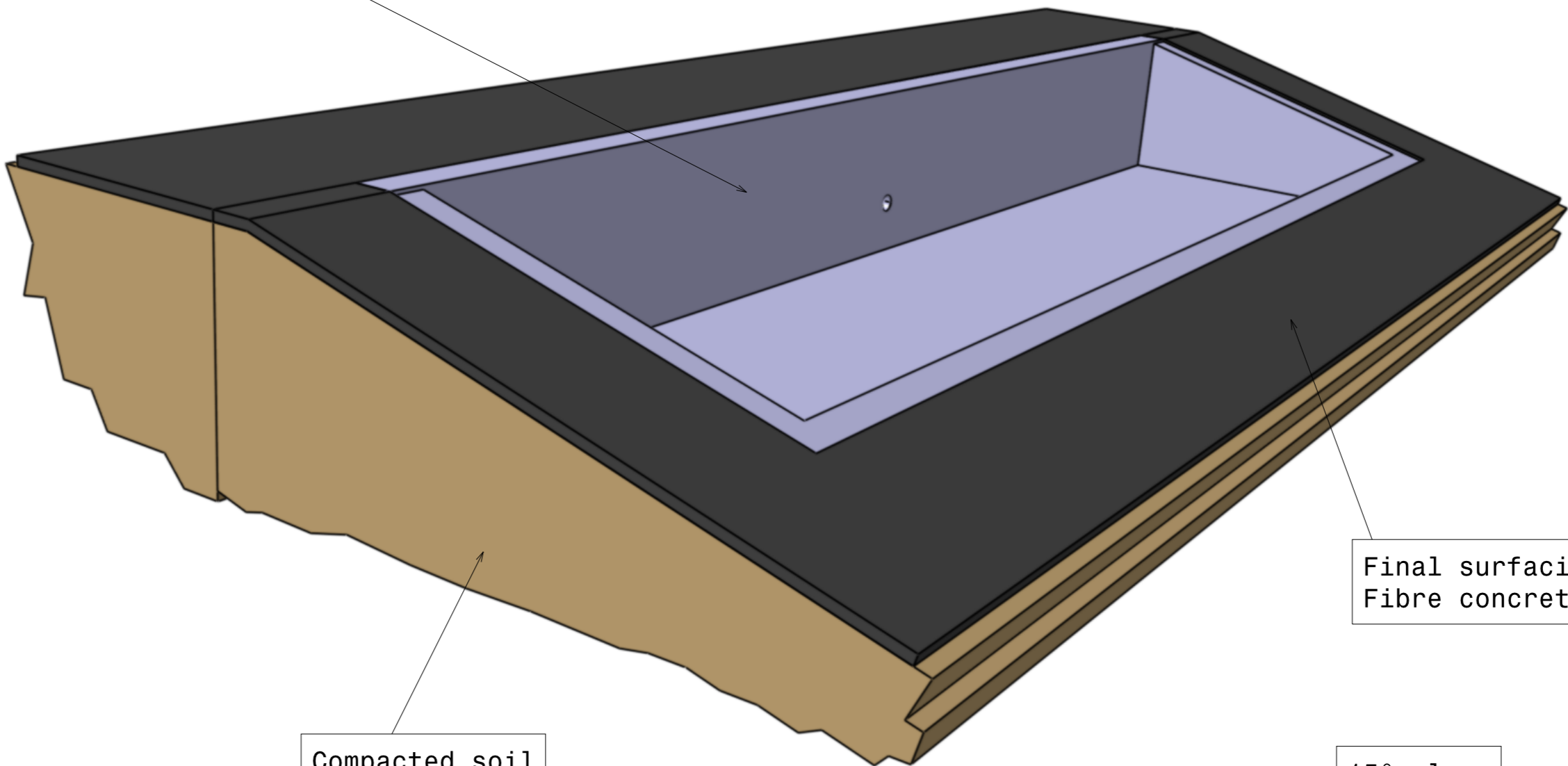

Compacted soil

Final surfacing
Fibre concrete or asphalt

15° slope

2

2

1

1

H G B A

DESIGNED BY: Romain	<h1>Overview</h1>		I	-
DATE: 01/12/2017			H	-
GENERAL TOLERANCE: +/- 1/4"			G	-
DATE: XXX	<h2>PROSTART</h2>		F	-
SIZE A3			E	-
SCALE 1:30	QUANTITY XXX	Concrete Pit GSx8S	D	-
			C	-
			B	-
			A	-
This drawing is our property; it can't be reproduced or communicated without our written agreement.				

SHEET
1/4

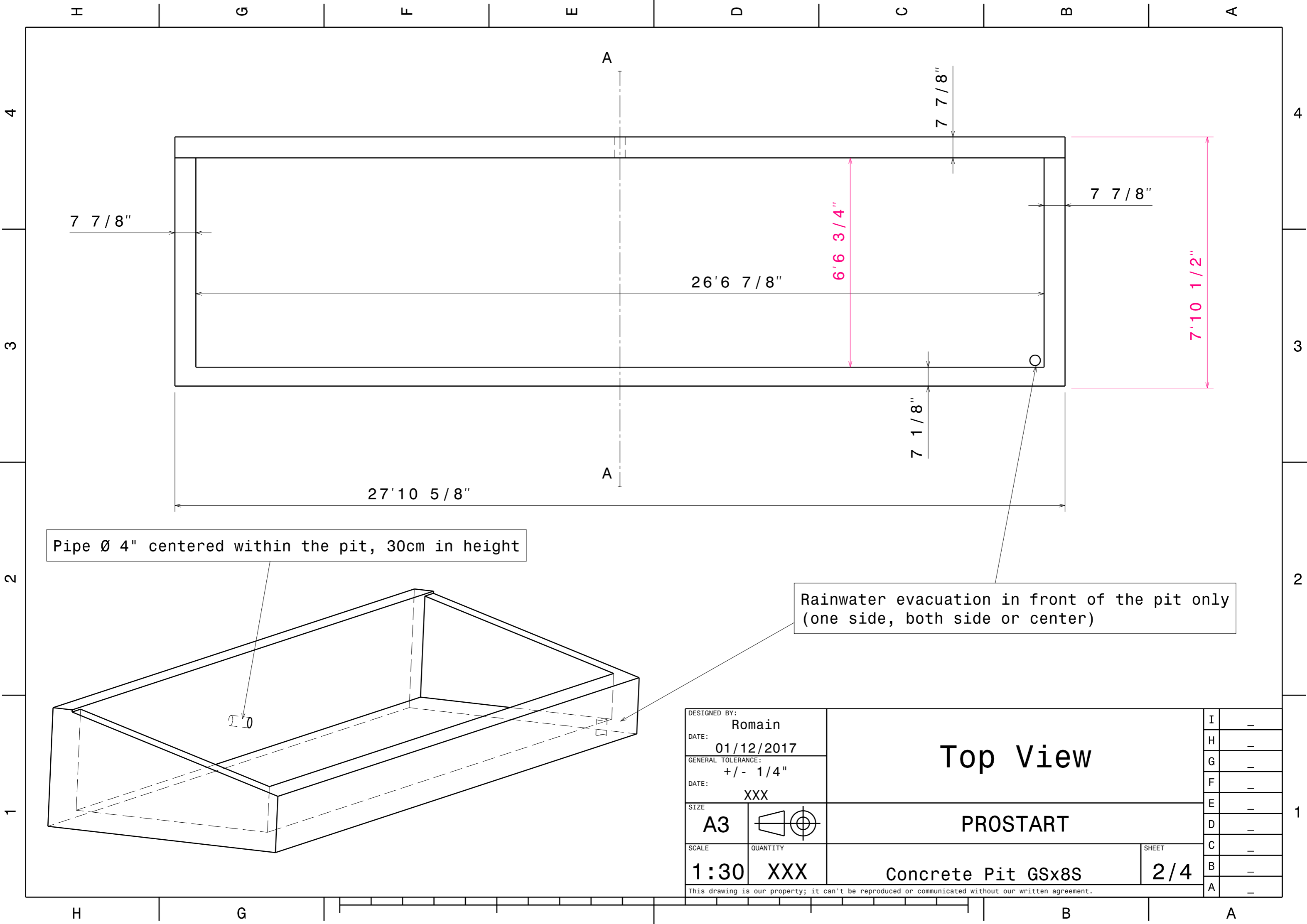

Pipe Ø 4" centered within the pit, 30cm in height

Rainwater evacuation in front of the pit only
(one side, both side or center)

DESIGNED BY: Romain		<h1>Top View</h1>	I	-
DATE: 01/12/2017			H	-
GENERAL TOLERANCE: +/- 1/4"		<h2>PROSTART</h2>	G	-
DATE: XXX			F	-
SIZE A3		<h3>Concrete Pit GSx8S</h3>	E	-
SCALE 1:30			QUANTITY XXX	D
		2/4	C	-
			B	-
			A	-

This drawing is our property; it can't be reproduced or communicated without our written agreement.

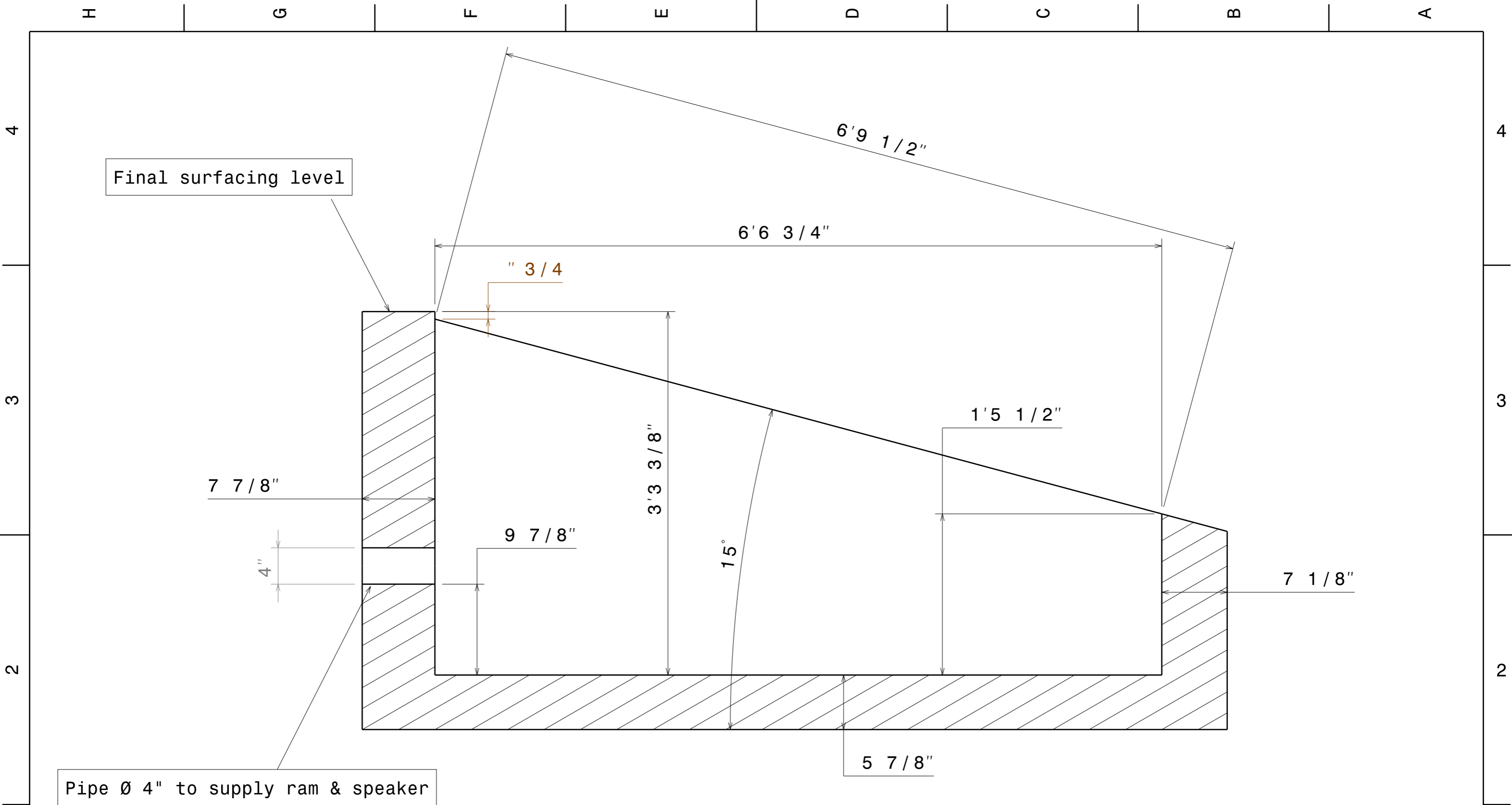

Final surfacing level

Pipe Ø 4" to supply ram & speaker

Maximum pipe length :
 100% electric gate GSE : 26 Feets
 Pneumatic gate GSP : 65 Feets

DESIGNED BY: Romain	<h1>A-A Cut</h1>	I	-
DATE: 01/12/2017		H	-
GENERAL TOLERANCE: +/- 1/4"		G	-
DATE: XXX	<h2>PROSTART</h2>	F	-
SIZE A3		E	-
SCALE 1:10	Concrete Pit GSx8S	D	-
QUANTITY XXX		C	-
		B	-
		A	-

This drawing is our property; it can't be reproduced or communicated without our written agreement.

H G F E D C B A

4

Final surfacing
Fibre concrete or asphalt

Structure under the gate

Quarter-barrel unit

Fibre concrete

Final surfacing
Fibre concrete or asphalt

3

2

Compacted soil

1

The final surfacing is put in place, preferably, after the gate installation to obtain the best possible rendering

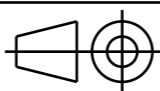
DESIGNED BY: Romain	Prostart Gate Side View
DATE: 01/12/2017	
GENERAL TOLERANCE: +/- 1/4"	PROSTART
DATE: XXX	
SIZE A3	
SCALE 1:15	QUANTITY XXX

Concrete Pit GSx8S		SHEET 4/4

I	-
H	-
G	-
F	-
E	-
D	-
C	-
B	-
A	-

This drawing is our property; it can't be reproduced or communicated without our written agreement.

H G B A

AID ON THE CONCRETE SLAB REALIZATION

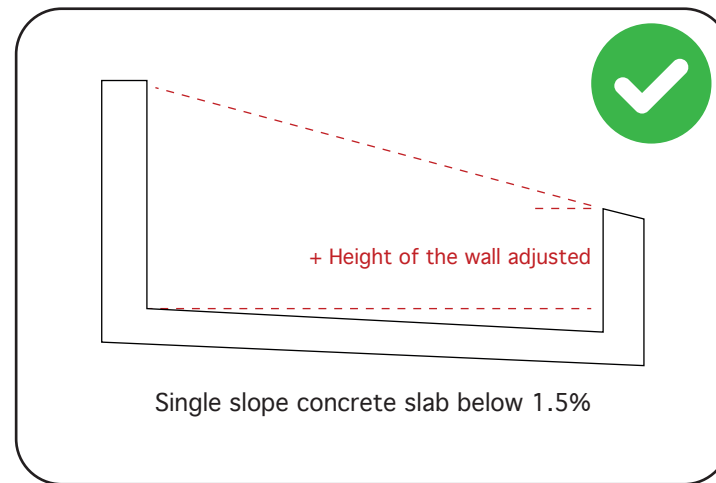
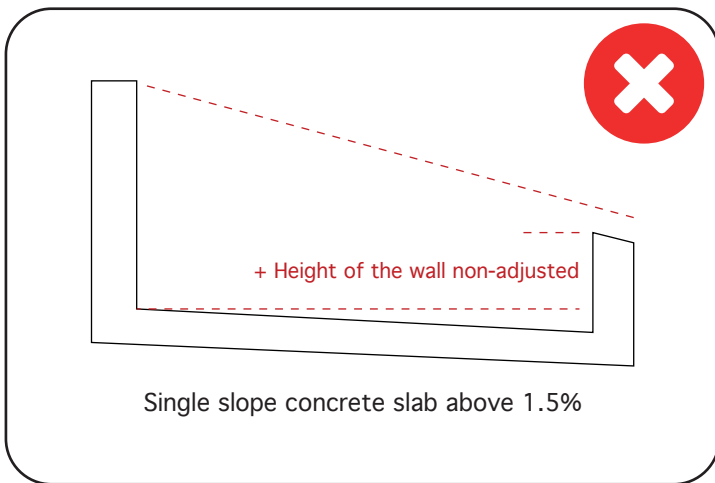
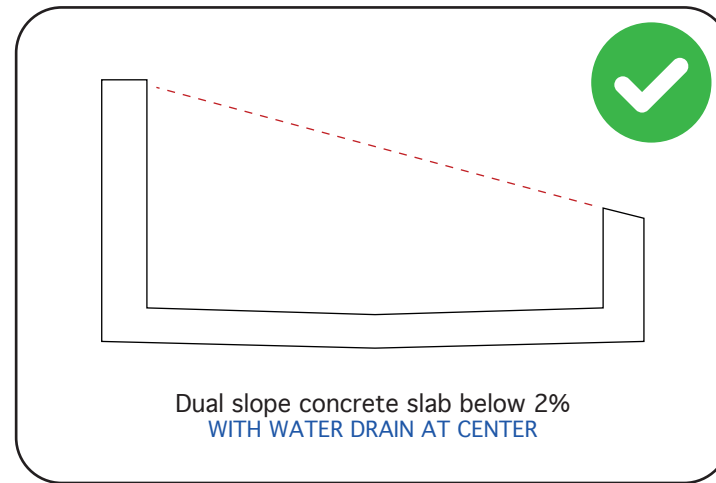
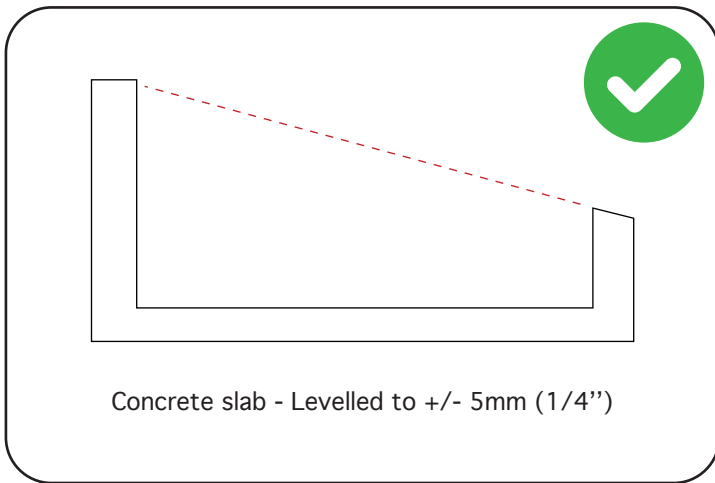

DESIGNED BY: Romain	<h2>AID ON FLOOR SLAB</h2>	I	-
DATE: 11/03/2016		H	-
GENERAL TOLERANCE: +/- 10mm		G	-
DATE: XXX	<h3>PROSTART</h3>	F	-
SIZE A3		E	-
SCALE 1:15		D	-
QUANTITY XXX		C	-
SHEET 4/4		B	-
This drawing is our property; it can't be reproduced or communicated without our written agreement.		A	-

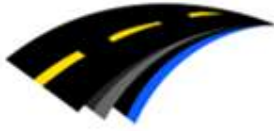

CENTRAL WASHINGTON ASPHALT, INC.

Serving all of Eastern Washington & Northeast Oregon

Corporate Office

PO Box 939
Moses Lake, WA 98837
(509) 765-5757

Wenatchee Office

385 E Penny Rd Ste 103
Wenatchee, WA 98801
(509) 662-6063

Tri-Cities Office

16004 E Field Rd
Benton City, WA 99320
(509) 588-5214

Milton-Freewater Office

53847 WW River Rd
Milton-Freewater, OR
(541) 938-5205

Yakima Office

202 N Ahtanum Ave
Wapato, WA 98951
(509) 866-4900

To:	Sam Mcpeck	Contact:	Sam Mcpeck
Address:	1210 Roberdeau St. Richland, WA 99354	Phone:	509-308-6944
		Fax:	
Project Name:	BMX Track -- HMA Placement	Bid Number:	2024-102GR
Project Location:	2002 Snyder St., Richland, WA	Bid Date:	8/30/2024

**We are pleased to quote the following project:
Any Questions please contact Gary Robins at 509-727-4072
See & Read Notes Below**

Item #	Item Description	Estimated Quantity	Unit	Unit Price	Total Price
Mobilization					
1	Mobilization	1.00	EACH	\$2,500.00	\$2,500.00
Subtotal for above Mobilization Items:					\$2,500.00
Washington State Sales Tax 8.70%:					\$217.50
Total Price for above Mobilization Items:					\$2,717.50
Phase 1					
2	Phase 1 - Start Area - Haul & Place 3" HMA Depth. G-Mix	2,520.00	SF	\$4.75	\$11,970.00
3	Phase 1 - Area Between Tracks - Haul & Place 3" HMA	260.00	SF	\$13.60	\$3,536.00
Subtotal for above Phase 1 Items:					\$15,506.00
Washington State Sales Tax 8.70%:					\$1,349.02
Total Price for above Phase 1 Items:					\$16,855.02
Phase 2					
4	Phase 2 - Shoot Area - Haul & Place HMA 3" Depth	2,312.00	SF	\$3.60	\$8,323.20
Subtotal for above Phase 2 Items:					\$8,323.20
Washington State Sales Tax 8.70%:					\$724.12
Total Price for above Phase 2 Items:					\$9,047.32
Bid Price Subtotal:					\$26,329.20
Total Washington State Sales Tax 8.70%:					\$2,290.64
Total Bid Price:					\$28,619.84

Notes:

- Quote Excludes: Preparation of Grade, Surveying, Testing, Pavement Markings, Saw Cutting, Prime Coat, Joint Sealant, Soil Sterilant, Utility Adjustments, Patching Of Utilities (if needed ADD \$150.00 EA.- unless otherwise negotiated with CWA personnel), Traffic Control, Permits, Fees, Bond (Add 2%).
- Central Washington Asphalt, Inc. is not responsible for designed cross slopes of 1% or less, as this may result in holding of water after paving is completed.
- Subgrade must be firm and unyielding.
- Central Washington Asphalt, Inc. proposed prices herein assumes that Central Washington Asphalt, Inc.' work hereunder will be substantially complete **on/before October 30**, unless otherwise approved by Central Washington Asphalt, Inc. in writing. Central Washington Asphalt, Inc. is not responsible for cold winter construction. Additional cost incurred by Central Washington Asphalt, Inc. for performing work during cold weather will be negotiated.
- Unless the contracting party has signed and returned this agreement with in *(7) days* of the date first stated above, Central Washington Asphalt, Inc. proposal shall be null and void.

- Central Washington Asphalt Inc. is hereby authorized to furnish all materials and labor required to complete the work mentioned above and according to the terms thereof. Interest on any unpaid balance over 30 days from the billing date will be charged at 1.5% per month. Central Washington Asphalt Inc. reserves the right to hold the owner responsible for any damages Central Washington Asphalt Inc. may incur through collections of monies owed by the owner(s) and not constricted or limited to the following: reasonable attorney's fees, court costs, interest, and all other legal expenses when pursuing payment by owner/prime contractor.
- This quote includes our standard form of insurance only.
- This quote sheet must be attached to and become part of any subcontract agreement.
- **Area to be ready to pave by others.**
- **Bid based on One Mobilization. If more than one are needed use same unit price as shown.**
- **Phase One Paving will need to be accessible by Backhoe for loading paver.**
- **CWA will not be responsible for any damage done by equipment, ie. Grass, Landscaping, Under ground pipes or irrigation. etc.**
- **Area Between Tracks will need to be saw cut prior to HMA Placement. Not included in quote.**

Payment Terms:

Net/10 Days; *unless otherwise specified by contract terms and conditions.*

Total price to be based on actual quantity or measurement unless otherwise specified.

Central Washington Asphalt, Inc. accepts all major Credit Cards. There will be a 3% fee added to your bill if a Credit Card is used for payment.

<p>ACCEPTED: The above prices, specifications and conditions are satisfactory and are hereby accepted.</p> <p>Buyer: _____</p> <p>Signature: _____</p> <p>Date of Acceptance: _____</p>	<p>CONFIRMED: Central Washington Asphalt Inc.</p> <p>Authorized Signature: _____</p> <p>Estimator: Gary Robins 509-727-4072 gary.robins@cwainc.us</p>
---	---



Lic. SUPERC790Q3
Pasco, WA 99301
P: 509.727.8934
MichaelCWelch@hotmail.com

PROPOSAL

Joel Garcia

JOB TITLE: BMX track
JOB LOCATION: Richland, WA

12x35 Foundation wall	\$10,355.94
12x35 staging area	\$5,200.00
30x40 waiting area	\$7,320.00
Staging Pit slab	\$5,200.00

*proposed cost before tax, if applicable

Contractor Agreement _____ Date _____

Subcontractor Agreement _____ Date _____



Lic. SUPERC790Q3
Pasco, WA 99301
P: 509.727.8934
MichaelCWelch@hotmail.com

SCOPE LETTER

This Scope Letter is provided by Superior Concrete and Polishing LLC is to be inclusive of the bid proposal and contract.

Our company will have complete access to floor with no other trades on it or working, unless preapproved with our foreman.

General Contractor will supply onsite trash receptacles sufficient for job site debris.

The following is a list of exclusions to this bid:

1. Temporary water and power
2. Offsite storage of materials and equipment
3. Layout of other trades
4. Installation of other trades materials
5. Heat and cover for winter work conditions
6. Insulation of any kind
7. Remobilization
8. Any fees for special inspectors
9. Any fees for permits

All material is guaranteed to be as specified. All work to be completed in a substantial workmanlike manner according to specifications submitted, per standard practices. Any alteration or deviation from specifications involving extra costs will be executed only upon written orders, and will become an extra charge over and above the estimate. All agreements contingent upon strikes, accidents, or delays beyond our control.

40% material deposit, scheduled payments due upon the completion of each phase. We reserve the right to stop all work in the event payment becomes grossly late and then until payment is received. Our remobilization charge is \$900 per occurrence.

No schedule will become binding until mutually agreed upon. This letter is to become part of the main contract between General Contractor and Superior Concrete and Polishing LLC. Where discrepancies exist between any written or oral agreement between parties, the stipulations in this bid proposal and scope letter shall govern. All rights reserved.





WELCOME TO THE EXPLANADA BARRERA
BMX

verline
Painting & More

Patio Covers
EXTERIOR

mustang signs

LEXAR















LODGING TAX ADVISORY COMMITTEE AGENDA ITEM ITEM COVERSHEET

Meeting Date: 10/14/2024

Agenda Category: Hotel/Motel Grant Applications

Prepared By: Mark Williams

Subject:

Tri-City Water Follies - Columbia Cup and Over the River Air Show

Department:

City Manager

Recommended Motion:

Summary:

Tri-City Water Follies Association will host a three-day Hydroplane Boat Races & Over the River Air Show event on July 25, 26, and 27. Tri-City Water Follies Association is requesting \$10,000 and has a total non-grant funded budget of \$1,285,000.

Fiscal Impact:

Tri-City Water Follies Association is requesting \$10,000.

Attachments:

- I. Tri-City Water Follies - Columbia Cup and Over the River Air Show



2025 Lodging Tax Grant Application

Please review the [LTAC Program Information](#) prior to beginning the application process.

Preview the application questions before you begin. The application is a one-time process; you cannot pause, save, or restart once you begin.

APPLICANT INFORMATION

*1. Name of Organization

Tri-City Water Follies Association

*2. Business or Agency Type

Non-Profit

*3. Attach Completed W-9 Form

W9.pdf

4. Non-Profit Agencies - Attach Proof

Non Profit Status.pdf

*5. Applicant Name

Mark Williams

6. Applicant Title or Organizational Role

Even Director

*7. Full Address

621 N. Gum Street
Suite A WA 99336

*8. Applicant Phone Number

(509) 783-4675

*9. Applicant Email Address

waterfolliesmark@gmail.com

GRANT DETAILS

*10. Dollar Amount of Grant Funding Requested

10,000.00

*11. Grant Use Type

Event

12. For events or projects on City-owned property, please provide the name of the City employee you have reviewed this application with.

SKIPPED

*13. Title of the Proposed Event or Project

Tri-City Water Follies Columbia Cup & Over the River Air Show

*14. Event or Project Description (will be used in the contract language if granted)

3 days of Hydroplane Boat Races & Over the River Air Show. We use Wade Park in Pasco and Columbia Park in Kennewick. We use the shoreline for the community to view the boat races and air show July 25, 26 and 27. The upcoming year, 2025, will be the 60th year for this community event.

Non-Grant Funding Sources and Amounts

15. Tourism Marketing - Name of Funding Source

SKIPPED

16. Tourism Marketing - Dollar Amount

SKIPPED

17. Event/Festival Marketing - Name of Funding Source

SKIPPED

18. Event/Festival Marketing - Dollar Amount

SKIPPED

19. Tourism Facility Operation - Name of Funding Source

SKIPPED

20. Tourism Facility Operation - Dollar Amount

SKIPPED

***21. TOTAL NON-GRANT FUNDING BUDGET - Dollar Amount**

1,285,000.00

Grant Funding Requested - Planned Amounts and Distribution

22. Event/Festival Marketing - Dollar Amount

SKIPPED

23. Tourism Marketing - Dollar Amount

10,000.00

24. Tourism Facility Operation - Dollar Amount

SKIPPED

***25. TOTAL OF GRANT FUNDS - Dollar Amount**

10,000.00

ATTENDANCE ESTIMATES

The State of Washington **requires** attendance estimates, here are the accepted methods of calculation:

Direct Count: Actual count of visitors using methods such as paid admissions or registrations, clicker counts at entry points, vehicle counts or number of chairs filled. A direct count may also include information collected directly from businesses, such as hotels, restaurants or tour guides, likely to be affected by an event.

Indirect Count: Estimate based on information related to the number of visitors such as raffle tickets sold, redeemed discount certificates, brochures handed out, police requirements for crowd control or visual estimates.

Representative Survey: Information collected directly from individual visitors/participants. A representative survey is a highly structured data collection tool, based on a defined random sample of participants, and the results can be reliably projected to the entire population attending an event and includes margin of error and confidence level.

Informal Survey: Information collected directly from individual visitors or participants in a non-random manner that is not representative of all visitors or participants. Informal survey results cannot be projected to the entire visitor population and provide a limited indicator of attendance because not all participants had an equal chance of being included in the survey.

Structured Estimate: Estimate produced by computing known information related to the event or location. For example, one jurisdiction estimated attendance by dividing the square footage of the event area by the international building code allowance for persons (3 square feet).

***26. Predicted Overall Attendance - Estimation Method Used**

Indirect Count

***27. Predicted Overall Attendance - Estimated Number**

70,000

***28. Predicted Attendance, 50+ Miles - Estimation Method Used**

Structured Estimate

***29. Predicted Attendance, 50+ Miles - Estimated Number**

15,000

***30. Predicted Attendance, Out of State, Out of Country - Estimation Method Used**

Structured Estimate

***31. Predicted Attendance, Out of State, Out of Country - Estimated Number**

10,000

***32. Predicted Attendance, Paid for Overnight Lodging - Estimation Method Used**

Structured Estimate

***33. Predicted Attendance, Paid for Overnight Lodging - Estimated Number**

15,000

***34. Predicted Attendance, Did Not Pay for Overnight Lodging - Estimation Method Used**

Indirect Count

***35. Predicted Attendance, Did Not Pay for Overnight Lodging - Estimated Number**

5,000

36. Predicted Paid Lodging Nights - Estimation Method Used

Structured Estimate

***37. Predicted Paid Lodging Nights - Estimated Number**

5,000

CONDITIONS FOR GRANT APPROVAL

38. Supplemental #1
SKM_C36824091112290.pdf

39. Supplement #2
SKIPPED

I acknowledge and agree to the below grant funding criteria:

1. I may be required to make a presentation to the advisory committee about my event/project.
2. All advertising will include the (provided) City of Richland logo and/or the phrase "Funding provided by City of Richland Lodging Tax Grant program."
3. I agree to submit marketing materials for approval by the Communications & Marketing Manager (or their designee) prior to publishing.
4. A final project report, including reporting requirements meeting state guidelines outlined in the LTAC Program Information document, and all supporting documents will be submitted to the City of Richland within 90 days of completion of the event or project AND must be expended within the calendar year in which they are granted.
5. I understand that grant progress will be monitored for compliance with scope and timeline.
6. If my event or project is on City-owned property, I have discussed this project with City staff and provided their name above.

***40. By typing my full name below, I agree to the above grant funding requirements, that I am authorized by my agency to submit this application and that all information provided herein is true and correct.**

Mark Williams

City of Richland - 625 Swift Blvd, MS 39 - Richland, WA 99352
www.ci.richland.wa.us/LodgingTax

5:09 PM
 08/20/24
 Accrual Basis

Tri-City Water Follies Assoc. Transaction Detail By Account January through December 2024

Type	Date	Num	Name	Memo	Clr	Split	Amount	Balance
7300 · Advertising & Marketing								
7305 · Digital Media								
Check	03/05/2024	EFT	Spotted Fox Digital	Webpage & S...		HAPO Checking	4,500.00	4,500.00
Check	04/03/2024	EFT	Spotted Fox Digital	Webpage & S...		HAPO Checking	380.00	4,880.00
Check	06/04/2024	EFT	Spotted Fox Digital	Webpage & S...		HAPO Checking	500.00	5,380.00
Check	06/04/2024	EFT	Spotted Fox Digital	Webpage & S...		HAPO Checking	600.00	5,980.00
Check	07/13/2024	EFT	Spotted Fox Digital	Webpage & S...		HAPO Checking	10,000.00	15,980.00
Total 7305 · Digital Media							15,980.00	15,980.00
7304 · Print Media								
Bill	05/20/2024		Home Town Values			2000 · Account...	547.00	547.00
Bill	06/13/2024		Home Town Values	July add		2000 · Account...	1,297.00	1,844.00
Bill	08/19/2024		Tri-Cities Area Journ...	Invoice #4703		2000 · Account...	1,165.00	3,009.00
Total 7304 · Print Media							3,009.00	3,009.00
7303 · Radio								
Bill	07/31/2024	11920	Stevenson Advertising	Radio Adverti...		2000 · Account...	792.00	792.00
Total 7303 · Radio							792.00	792.00
7302 · Television								
Bill	07/31/2024	11920	Stevenson Advertising	TV Advertising		2000 · Account...	9,527.50	9,527.50
Bill	08/15/2024	22817...	SWXOU			2000 · Account...	5,000.00	14,527.50
Total 7302 · Television							14,527.50	14,527.50
7301 · Printing & Production								
Bill	07/31/2024	05	Fitzgerald, Jason	Graphic Design		2000 · Account...	3,500.00	3,500.00
Total 7301 · Printing & Production							3,500.00	3,500.00
Total 7300 · Advertising & Marketing							37,808.50	37,808.50
TOTAL							37,808.50	37,808.50



LODGING TAX ADVISORY COMMITTEE AGENDA ITEM ITEM COVERSHEET

Meeting Date: 10/14/2024

Agenda Category: Hotel/Motel Grant Applications

Prepared By: David Comstock

Subject:

Friends of Badger Mountain - Little Badger Mountain Loop Trail Master Plan Implementation

Department:

City Manager

Recommended Motion:

Summary:

Friends of Badger Mountain is seeking \$326,520 to complete the Little Badger Mountain Loop Trail Master Plan. The project includes the following three components:

- 1) Little Badger Mountain Loop Trail Master Plan primary trailhead design,
- 2) Public trail construction (Meadow Hills Dr to Badger Mountain Centennial Preserve) including the mid-block crossing of Queensgate Dr,
- 3) Self-guided audio tours in partnership with the National Park Service, Ice Age Floods National Geologic Trail for the National Park Service mobile App to promote the City of Richland, Trailhead Park and Little Badger Mountain Loop trails as Ice Age Floods destinations.

Fiscal Impact:

Friends of Badger Mountain is requesting \$326,520.

Attachments:

- I. Friends of Badger Mountain - Little Badger Mountain Loop Trail Master Plan Implementation

24-016 FOBM - LITTLE BADGER MASTER PLAN

Submission # 3497553
IP Address 68.186.68.97
Submission Recorded On 09/20/2024 8:32 AM
Time to Take Survey 28 minutes, 43 seconds

Page 1 - Applicant Information



2025 Lodging Tax Grant Application

Please review the [LTAC Program Information](#) prior to beginning the application process.

Preview the application questions before you begin. The application is a one-time process; you cannot pause, save, or restart once you begin.

APPLICANT INFORMATION

- * **1. Name of Organization** ?
Friends of Badger Mountain
- * **2. Business or Agency Type**
Non-Profit
- * **3. Attach Completed W-9 Form** ?
W-9 for Friends of Badger Mountain.pdf
- 4. Non-Profit Agencies - Attach Proof** ?
FOBM IRS EIN 84-1702655 Letter for 501c3.pdf
- * **5. Applicant Name** ?
Director David Comstock
- 6. Applicant Title or Organizational Role**
FOBM Board of Directors, Member at Large and Project Manager
- * **7. Full Address**
1301 Brookwood Avenue
Richland Washington 99352
- * **8. Applicant Phone Number** ?
(509) 521-8226
- * **9. Applicant Email Address** ?
dcomstock1@gmail.com

Page 2 - Grant Details

GRANT DETAILS

- * **10. Dollar Amount of Grant Funding Requested** ?
326,520.00
- * **11. Grant Use Type** ?
Project: on City-owned Property or Facility
- 12. For events or projects on City-owned property, please provide the name of the City employee you have reviewed this application with.** ?
Chris Waite City of Richland, Parks and Public Facilities Director
- * **13. Title of the Proposed Event or Project** ?
Little Badger Mountain Loop Trail Master Plan Implementation
- * **14. Event or Project Description (will be used in the contract language if granted)** ?
Three components 1) Little Badger Mountain Loop Trail Master Plan primary trailhead design, 2) Public trail construction (Meadow Hills Dr to Badger Mountain Centennial Preserve) including the mid-block crossing of Queensgate Dr, 3) Self-guided audio tours in partnership with the National Park Service, Ice Age Floods National Geologic Trail for the National Park Service mobile App to promote the City of Richland, Trailhead Park and Little Badger Mountain Loop trails as Ice Age Floods destinations

Non-Grant Funding Sources and Amounts

- 15. Tourism Marketing - Name of Funding Source** ?
N/A
- 16. Tourism Marketing - Dollar Amount** ?
SKIPPED
- 17. Event/Festival Marketing - Name of Funding Source** ?
N/A

18. Event/Festival Marketing - Dollar Amount ?

SKIPPED

19. Tourism Facility Operation - Name of Funding Source ?

Friends of Badger Mountain

20. Tourism Facility Operation - Dollar Amount ?

90,000.00

*** 21. TOTAL NON-GRANT FUNDING BUDGET - Dollar Amount** ?

90,000.00

Grant Funding Requested - Planned Amounts and Distribution

22. Event/Festival Marketing - Dollar Amount ?

SKIPPED

23. Tourism Marketing - Dollar Amount ?

SKIPPED

24. Tourism Facility Operation - Dollar Amount ?

326,520.00

*** 25. TOTAL OF GRANT FUNDS - Dollar Amount** ?

326,520.00

ATTENDANCE ESTIMATES

The State of Washington **requires** attendance estimates, here are the accepted methods of calculation:

Direct Count: Actual count of visitors using methods such as paid admissions or registrations, clicker counts at entry points, vehicle counts or number of chairs filled. A direct count may also include information collected directly from businesses, such as hotels, restaurants or tour guides, likely to be affected by an event.

Indirect Count: Estimate based on information related to the number of visitors such as raffle tickets sold, redeemed discount certificates, brochures handed out, police requirements for crowd control or visual estimates.

Representative Survey: Information collected directly from individual visitors/participants. A representative survey is a highly structured data collection tool, based on a defined random sample of participants, and the results can be reliably projected to the entire population attending an event and includes margin of error and confidence level.

Informal Survey: Information collected directly from individual visitors or participants in a non-random manner that is not representative of all visitors or participants. Informal survey results cannot be projected to the entire visitor population and provide a limited indicator of attendance because not all participants had an equal chance of being included in the survey.

Structured Estimate: Estimate produced by computing known information related to the event or location. For example, one jurisdiction estimated attendance by dividing the square footage of the event area by the international building code allowance for persons (3 square feet).

*** 26. Predicted Overall Attendance - Estimation Method Used** ?

Direct Count

*** 27. Predicted Overall Attendance - Estimated Number** ?

664

*** 28. Predicted Attendance, 50+ Miles - Estimation Method Used** ?

Direct Count

*** 29. Predicted Attendance, 50+ Miles - Estimated Number** ?

369

*** 30. Predicted Attendance, Out of State, Out of Country - Estimation Method Used** ?

Direct Count

*** 31. Predicted Attendance, Out of State, Out of Country - Estimated Number** ?

90

*** 32. Predicted Attendance, Paid for Overnight Lodging - Estimation Method Used** ?

Structured Estimate

*** 33. Predicted Attendance, Paid for Overnight Lodging - Estimated Number** ?

146

*** 34. Predicted Attendance, Did Not Pay for Overnight Lodging - Estimation Method Used** ?

Structured Estimate

*** 35. Predicted Attendance, Did Not Pay for Overnight Lodging - Estimated Number** ?

518

36. Predicted Paid Lodging Nights - Estimation Method Used ?

Structured Estimate

*** 37. Predicted Paid Lodging Nights - Estimated Number** ?

73

Page 4 - Conditions for Grant Approval

CONDITIONS FOR GRANT APPROVAL

38. Supplemental #1 ?

Q14 Project Description - FOBM 2025 Lodging Tax Grant Application.pdf

39. Supplement #2 ?

Letter for Friend of Badger Mountain 2024 Richland Grant from the National Park Service.pdf

I acknowledge and agree to the below grant funding criteria:

1. I may be required to make a presentation to the advisory committee about my event/project.
2. All advertising will include the (provided) City of Richland logo and/or the phrase "Funding provided by City of Richland Lodging Tax Grant program."
3. I agree to submit marketing materials for approval by the Communications & Marketing Manager (or their designee) prior to publishing.
4. A final project report, including reporting requirements meeting state guidelines outlined in the LTAC Program Information document, and all supporting documents will be submitted to the City of Richland within 90 days of completion of the event or project AND must be expended within the calendar year in which they are granted.
5. I understand that grant progress will be monitored for compliance with scope and timeline.
6. If my event or project is on City-owned property, I have discussed this project with City staff and provided their name above.

*

40. By typing my full name below, I agree to the above grant funding requirements, that I am authorized by my agency to submit this application and that all information provided herein is true and correct. ?

David Comstock

City of Richland - 625 Swift Blvd, MS 39 - Richland, WA 99352
www.ci.richland.wa.us/LodgingTax

2025 – Lodging Tax Grant – Friends of Badger Mountain (FOBM) Application

***13 Title:** Little Badger Mountain Loop Trail Master Plan Implementation

***14 Project Description:**

This project grant application has three components: 1) Little Badger Mountain Loop Trail Master Plan Implementation, primary trailhead design, 2) Public trail construction (Meadow Hills Dr to Badger Mountain Centennial Preserve) including the mid-block crossing of Queensgate Dr, 3) Self-guided audio tours in partnership with the National Park Service, Ice Age Floods National Geologic Trail for the National Park Service mobile App to promote the City of Richland, Trailhead Park and Little Badger Mountain Loop trails as Ice Age Floods destinations for visitors to travel to Richland for outdoor recreation & education. Supporting details and Figure 1. map below:

1) Little Badger Mountain Loop Trail Master Plan Implementation – Primary Trailhead Design

The design of the primary trailhead is one of the next steps needed to implement the City of Richland, approved Little Badger Mountain Loop Trail Master Plan (City Master Plan). The goal of this Lodging Tax grant project is to prepare a shovel ready design for the Little Badger primary trailhead. Future grants to the WA State Recreation and Conservation Office and Port of Kennewick will seek construction funding to build this primary trailhead.

Lodging Tax Grant Cost: PBS Design & Engineering Service: \$232,060 (see attached PBS proposal dated 9/19/24)

Future Non-Grant Funding Sources: With a shovel ready primary trailhead design City of Richland in partnership with FOBM will be able to apply for WA State, Recreation and Conservation Office (RCO) and Port of Kennewick funds for construction of primary trailhead.

City of Richland Responsibilities: Provide access to City of Richland park parcel, Queensgate Drive at Parcel #134982012049006 for PBS engineering activities including PBS Proposal, **Phase 001 – Topographic and Boundary Survey & Phase 002 – Geotechnical Engineering Field Work / Test Pits.**

City of Richland Responsibilities: Provide oversight and attend and provide materials for PBS Proposal, **Phase 005 - Public Involvement process.**

2) Public trail construction (Meadow Hills Dr to Badger Mountain Centennial Preserve) including the mid-block crossing of Queensgate Dr

Friends of Badger Mountain (FOBM) volunteers have completed trail section “F” from the City Little Badger master plan. During this Lodging Tax grant, FOBM volunteers will complete trail sections “A” and “C” from the City’s master plan, connecting the Queensgate Drive mid-block crossing to the Meadow Hills Drive secondary trailhead. In addition, FOBM volunteers and subcontractors will complete the trail from the Queensgate Drive mid-block crossing to the Badger Mountain Centennial Preserve. This new trail will increase City park and recreational opportunities for the general public and connect this new City park to the most popular park in Benton County’s Park System (Badger Mountain Centennial Preserve).

Lodging Tax Grant Cost: Sub-contract cost for construction of the Queensgate Mid-Block crossing \$75,000 and PBS Tittle III Engineering Service: \$15,000

Future Non-Grant Funding Sources: Non-Profit Friends of Badger Mountain will provide additional funding for the public trail construction. Estimated value: \$90,000

- A. Friends of Badger Mountain (FOBM) volunteers will build a portion of trail section “A” from the City Little Badger master plan. Estimated cost \$14,000 FOBM funding
 - a. Equipment rental: excavator, loader and hauler rental estimated \$10,000
 - b. Material: gravel and hand tools estimated \$2,500
 - c. In-Kind Volunteer labor: 100 hours of FOBM Volunteer time estimated \$1600
- B. Friends of Badger Mountain (FOBM) volunteers will build a portion of trail section “C” from the City Little Badger master plan. Estimated cost \$14,000 FOBM funding
 - a. Equipment rental: excavator, loader and hauler rental estimated \$10,000
 - b. Material: gravel and hand tools estimated \$2,500
 - c. In-Kind Volunteer labor: 100 hours of FOBM Volunteer time estimated \$1600
- C. Friends of Badger Mountain (FOBM) sub-contractor & volunteers will build trail from Queensgate Drive Mid-Block Crossing to Badger Mountain Centennial Preserve.
 - a. 70 hours of FOBM volunteer time (estimated value \$1100), no new material
 - b. Construction Sub-Contractor = Estimated construction cost \$62,000

City of Richland Responsibilities: Approve Trail Construction Agreement for FOBM volunteers to build trail on City park property.

City of Richland Responsibilities: Review and approve actual trail location prior to trail construction on City park property.

3) Self-guided audio tours in partnership with the National Park Service

Friends of Badger Mountain is a National Park Service partner to the Ice Age Floods National Geologic Trail. Currently on the National Park Service Mobile App there is a self-guided tour starting in the City of Richland, Trailhead Park. This component of the project will enhance the existing self-guided tours with audio recordings and then create a new self-guided tour for the Little Badger Mountain Loop interpretive trail also with audio recordings. The new Little Badger Mountain Preserve trailhead and interpretive trail will become an important destination along the Ice Age Floods National Geologic Trail. Following completion of the trailhead and interpretive loop, the Ice Age Floods National Geologic Trail interpretive map will be updated to show this important destination as a point of interest along the National Park Service’s national trail system.

Lodging Tax Grant Cost: Focal Point Service: \$3,460 (see attached Focal Point proposal)

Figure 1. 2025 – Lodging Tax Grant Project Map

2025 – Lodging Tax Grant – Friends of Badger Mountain (FOBM) Application

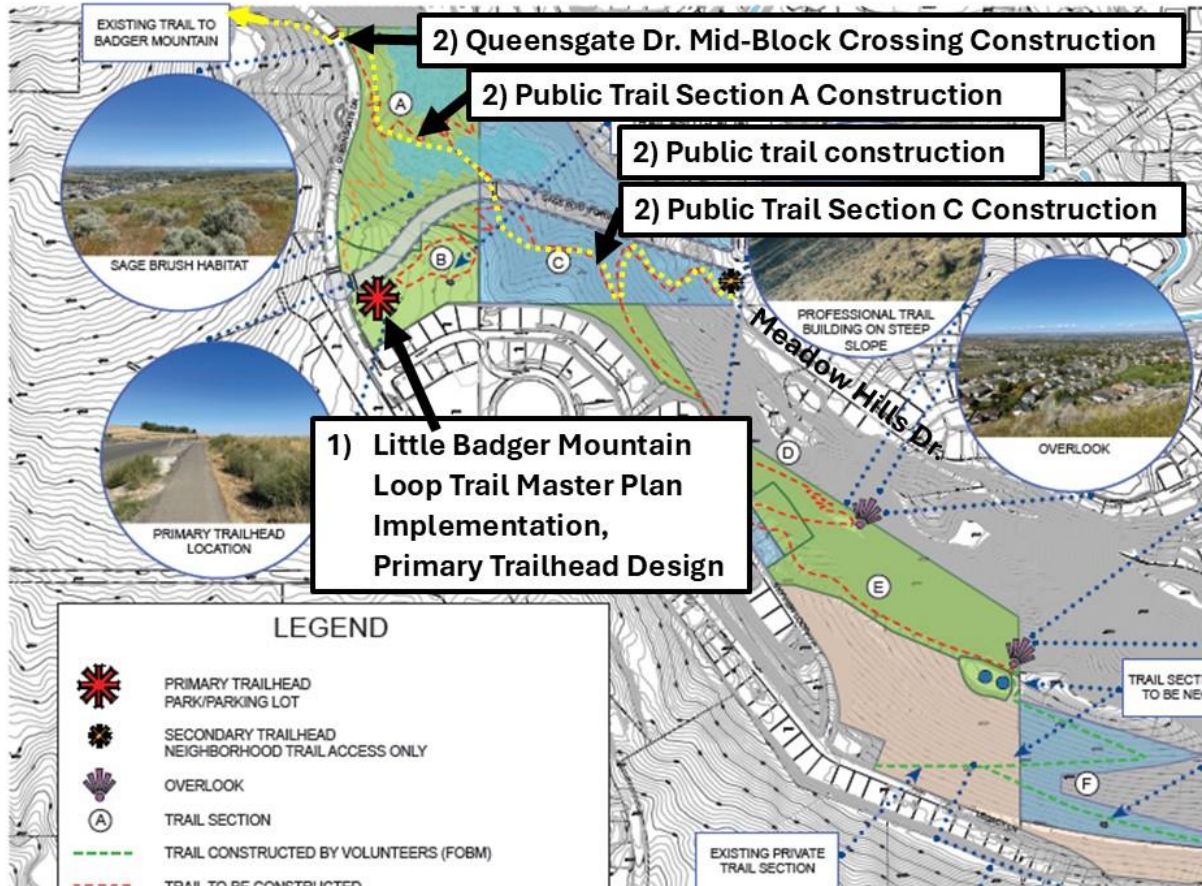



United States Department of the Interior

NATIONAL PARK SERVICE
ICE AGE FLOODS NATIONAL GEOLOGIC TRAIL
1008 CREST DRIVE
COULEE DAM, WA 99116-1259



City of Richland
Hotel/Motel Tax Grant
Attn: Gail Everett
Communications & Marketing Specialist
625 Swift Boulevard
Richland, WA 99352
geverett@ci.richland.wa.us

August 11, 2024

Dear City of Richland's Hotel/Motel Tax Grant Committee,

Ice Age Floods National Geologic Trail is writing you in support of the Friends of Badger Mountain's proposal for a City of Richland Hotel/Motel tax grant. We support their request for grant funds to design the Little Badger Mountain trailhead parking lot and interpretive loop.

The Friends of Badger Mountain are actively seeking to preserve landscapes and features which are significant to the Ice Age Floods National Geologic Trail. The National Park Service estimates that millions of visitors enjoy components of the Ice Age Floods National Geologic Trail each year. If the Friends of Badger Mountain receive this grant, they will be actively working to bring some of those visitors to the City of Richland.

The Friends of Badger Mountain are currently working on an interconnected trail system that includes the development of interpretive and educational wayside exhibits specifically focused on telling the stories of the Ice Age Floods. Additionally, they are engaged in enhancing the awareness of the Ice Age Floods National Geologic Trail through supportive efforts to grow presence both physically and digitally.

The growing connection between Ice Age Floods National Geologic Trail and Friends of Badger Mountain brings enormous benefits to the visitor experience and furthers both local and National Parks Service goals. The Ice Age Floods National Geologic Trail has been fortunate to have the Friends of Badger Mountain as a partner since 2022 and envisions many more rewarding years of collaboration ahead.

If awarded the grant, the new Little Badger Mountain Preserve trailhead and interpretive trail will become an important destination along the Ice Age Floods National Geologic Trail. Following completion of this project, the Ice Age Floods National Geologic Trail interpretive map will be updated to show this important destination as a point of interest along the National Park Service's national trail system.

Please to reach out directly to the contact information provided below if you need any additional information or have any questions or concerns.

Sincerely,

JUSTIN
RADFORD
Digitally signed by
JUSTIN RADFORD
Date: 2024.08.11
12:10:58 -07'00'

Justin Radford
Acting Park Manager
Lake Roosevelt National Recreation Area
Ice Age Floods National Geologic Trail
1008 Crest Drive
Coulee Dam, WA 99116

Park - 509-754-7800
Mobile - 509-237-9722

EXPERIENCE YOUR AMERICA™

The National Park Service cares for special places saved by the American people so that all may experience our heritage.



**UNIVERSITY OF
PLYMOUTH**

School of Geography, Earth
and Environmental Sciences

18 August 2024

David Comstock
Friends of Badger Mountain
PO Box 24
Richland
WA, 99352
USA

Dear David

Re: Support for Friends of Badger Mountain

I am writing in connection with our annual field class visits to Richland, Washington, during which we work with Friends of Badger Mountain and other key local stakeholders. Our visit to Richland this April was very successful and I'd like to thank you for your time and efforts once again. It was great to continue our run of visits after the hiatus imposed by covid restrictions in 2020 and 2021.

As you know, each year we run a geography field class for second year undergraduate students (the equivalent of juniors) from the University of Plymouth, England. The key theme of the trip is environmental change and management, and over the last eight trips the programme of activities you have led for us has been a key part of our syllabus. The students very much enjoy your guided hike on Badger Mountain (please see attached picture)!

Your work on Badger, Little Badger and Candy Mountains is thus an important reason why we come to stay in Richland, and so long as you are willing we intend to continue our visits to Richland in the Spring; our next one will be in April 2026.

We have now been running this trip from Plymouth annually or biennially since 2007, and have brought around 500 students (and 14 different faculty members) to stay in Richland. Our trip accounts between 2014 and 2024 show a total expenditure on hotel accommodation in Richland – initially at the Hampton Inn and subsequently at the Homewood Suites – of \$53,903:

2024: \$2,042
2023: \$11,788
2022: \$12,346
2019: \$3,735
2018: \$10,344

School of Geography, Earth and
Environmental Sciences
University of Plymouth
Drake Circus
Plymouth, PL4 8AA
United Kingdom

T +44 (0) 1752 584709
F +44 (0) 1752 584710
E geesenquiries@plymouth.ac.uk
W www.plymouth.ac.uk

Professor Jon Shaw, BSc PGDip PhD FRGS FHEA
Head of School

2017: \$6,028
2016: \$4,760
2014: \$2,860
Total: \$53,903

In the years before 2014 we stayed at the Hampton Inn, Richland, and the Days Inn, Richland, although university accounts are less accessible from 2007-2013. Still, with an average of 30 students and 4 staff on each trip, my notes show we spent a further \$7000 on hotels, making a total of around \$61,000 in non-adjusted dollars on Richland accommodations alone.

As I also said in my previous letter, a key reason why we come to Richland is to work with you and your colleagues at Friends of Badger Mountain, as this provides us with excellent insights into how community-led, grassroots organisations are capable of working to protect urban and semi-urban landscapes. It is the best example we know of on the route of our trip – hence our intention to continue to visit and to work with you.

I wish you all the very best with your continued efforts to raise funds, and look forward to learning of your progress in 2026 when we return.

With all best wishes,



Professor Jon Shaw
Head of School
jon.shaw@plymouth.ac.uk



LODGING TAX ADVISORY COMMITTEE AGENDA ITEM ITEM COVERSHEET

Meeting Date: 10/14/2024

Agenda Category: Hotel/Motel Grant Applications

Prepared By: Laci Tolar

Subject:

FORMEC - Apple Cup, ZMax Cars Tour, ARCA Series West, and Fall Classic

Department:

City Manager

Recommended Motion:

Summary:

Upcoming racing events for 2025 include the Apple Cup, a 4-day event (2 for attendees) - Zmax National Series (2-day event), Arca Series West (2-day event with practice), and the Fall Classic (4-day event). They are requesting \$40,000 with a budget of \$528,695

Fiscal Impact:

FORMEC is requesting \$40,000

Attachments:

- I. FORMEC - Apple Cup, ZMax Cars Tour, ARCA Series West, and Fall Classic

1. Name of Organization 9.19.2024
FORMEC
2. Non Profit - Economic Development
3. W9 attached
4. Non Profit Status - attached
5. Red Mountain Event Center | Tricity Raceway
6. Laci Tolar | President
7. 8280 W VAN GIESEN ST WEST RICHLAND, WA
8. 509-619-4477
9. RMECEVENTS@GMAIL.COM
10. REQUESTED AMOUNT \$40,000
11. EVENT
12. NA
13. APPLE CUP | ZMAX CARS TOUR | ARCA SERIES WEST | FALL CLASSIC
14. Apple Cup 4 day event (2 for attendees) - Zmax National Series (2day event)
Arca Series West (2day event with practice) - Fall Classic (4day event)

Apple Cup (April) 4 day Event

The 56th Running Apple Cup at Tri-City Raceway is a historic short-track race in Washington, known for its thrilling Super Late Model competition with supporting divisions. It draws large crowds and boosts the local economy with increased tourism and business activity.

The ZMAX Cars Tour (June or September) 2 Day NATIONAL

is a top-tier late-model stock car National series that occasionally stops on the West Coast. It features intense, competitive racing and attracts fans, teams, and media, generating economic benefits for host cities like Irwindale Speedway in California.

The NASCAR ARCA Menards Series West (August working on date change) 2 day Event NATIONAL was our largest event to date, & brought star power to Tri-Cities with Greg Biffle. It showcases emerging talent, drawing fans and media, which boosts our local economy through tourism and related business activity.

The Fall Classic at Tri-City Raceway (October) 4 day is a marquee late-model race that caps the season & is the largest stock car race on the west coast. Known for its high-speed action, it draws top drivers and fans, creating a significant economic impact on the local community.

Non-Grant Funding Sources and Amounts

15. Tourism Marketing - Name of Funding Source

na

16. Tourism Marketing – Dollar Amount

82,380

17. Event/Festival Marketing - Name of Funding Source

na

18. Event/Festival Marketing – Dollar Amount

82,380

19. Tourism Facility Operation - Name of Funding Source

na

20. Tourism Facility Operation – Dollar Amount

528,695

*21. TOTAL NON-GRANT

528,695

FUNDING BUDGET – Dollar Amount Grant Funding Requested - Planned
Amounts and Distribution

22. Event/Festival Marketing – Dollar Amount

\$45,000

23. Tourism Marketing – Dollar Amount

Included

24. Tourism Facility Operation – Dollar Amount

included

*25. TOTAL OF GRANT FUNDS – Dollar Amount

\$45,000

*26. Predicted Overall Attendance - Estimation Method Used

Direct Count + Structured Estimate

*27. Predicted Overall Attendance - Estimated Number

21,798

*28. Predicted Attendance, 50+ Miles - Estimation Method Used

Direct Account - Structured Estimate

*29. Predicted Attendance, 50+ Miles - Estimated Number

8719

*30. Predicted Attendance, Out of State, Out of Country - Estimation Method Used

Direct + Survey

*31. Predicted Attendance, Out of State, Out of Country - Estimated Number 4359

*32. Predicted Attendance, Paid for Overnight Lodging - Estimation Method Used- Direct +survey

*33. Predicted Attendance, Paid for Overnight Lodging - Estimated Number 4359

*34. Predicted Attendance, Did Not Pay for Overnight Lodging - Estimation Method Used
Direct/ Survey

*35. Predicted Attendance, Did Not Pay for Overnight Lodging - Estimated Number- Direct 17439

36. Predicted Paid Lodging Nights - Estimation Method Used
Survey, direct count

*37. Predicted Paid Lodging Nights - Estimated Number 4359

38. Supplemental #1 Maximum size allowed: 10 MB Allowed types: .jpg, .jpeg, .png, .pdf see attached info

39. Supplement #2 Maximum size allowed: 10 MB Allowed types: .jpg, .jpeg, .png, .pdf seed attached info

I acknowledge and agree to the below grant funding criteria: • I may be required to make a presentation to the advisory committee about my event/project. • All advertising will include the (provided) City of Richland logo and/or the phrase "Funding provided by City of Richland Lodging Tax Grant program." • I agree to submit marketing materials for approval by the Communications & Marketing Manager (or their designee) prior to publishing. • A final project report, including reporting requirements meeting state guidelines outlined in the LTAC Program Information document, and all supporting documents will be submitted to the City of Richland within 90 days of completion of the event or project AND must be expended within the calendar year in which they are granted. • I understand that grant progress will be monitored for compliance with scope and timeline. *40. By typing my full name below, I agree to the above grant funding requirements, that I am authorized by my agency to submit this application and that all information provided herein is true and correct

Laci Tolar
President
FORMEC | RED MOUNTAIN EVENT CENTER

14. Apple Cup 4 day event (2 for attendees) - Zmax National Series (2day event)
Arca Series West (2day event with practice) - Fall Classic (4day event)

Apple Cup (April) 4 day Event

The 56th Running Apple Cup at Tri-City Raceway is a historic short-track race in Washington, known for its thrilling Super Late Model competition with supporting divisions. It draws large crowds and boosts the local economy with increased tourism and business activity.

The ZMAX Cars Tour (June or September) 2 Day NATIONAL

is a top-tier late-model stock car National series that occasionally stops on the West Coast. It features intense, competitive racing and attracts fans, teams, and media, generating economic benefits for host cities like Irwindale Speedway in California.

The NASCAR ARCA Menards Series West (August working on date change)

2 day Event NATIONAL was our largest event to date, & brought star power to Tri-Cities with Greg Biffle. It showcases emerging talent, drawing fans and media, which boosts our local economy through tourism and related business activity.

The Fall Classic at Tri-City Raceway (October) 4 day

is a marquee late-model race that caps the season & is the largest stock car race on the west coast. Known for its high-speed action, it draws top drivers and fans, creating a significant economic impact on the local community.

9.19.2024

The Nations Only
1/2 TRIOVAL Racetrack!

West Richland's



- **MOTORSPORT EPICENTER**
- **CORPORATE EVENTS**
- **OUTDOOR EVENT CENTER**

NATIONAL VENUE

racewashington.com
redmountaineventcenter.com

rmecevents@gmail.com

WHO WE ARE

Friends of Red Mountain Event Center (FORMEC) is a non-profit organization with a singular focus on promoting economic development in our region.

Our dedicated team of visionaries has worked tirelessly to build an exceptional facility from the ground up, resulting in the nationally recognized Tri-City Raceway.

As the Nation's only 1/2 mile paved Trioval racetrack, Tri-City Raceway has become a magnet for competitors and fans alike, drawing individuals from all across the country.

Looking ahead to the next four years, we have ambitious plans to transform this facility into a nationwide epicenter for motorsports and concerts. We aim to further elevate the profile of Tri-City Raceway, solidifying its status as a premier destination for motorsports enthusiasts and music aficionados alike. With a keen focus on growth and expansion, we are committed to creating an unforgettable experience for all who visit our venue.

By partnering with local businesses, sponsors, and community organizations, we are working tirelessly to bring our vision to fruition. As we continue to work towards our goal, we invite all individuals to join us on this exciting journey as we strive to make Tri-City Raceway a beacon of economic development and entertainment in our region. Together, we can achieve great things and leave a lasting impact on our community.

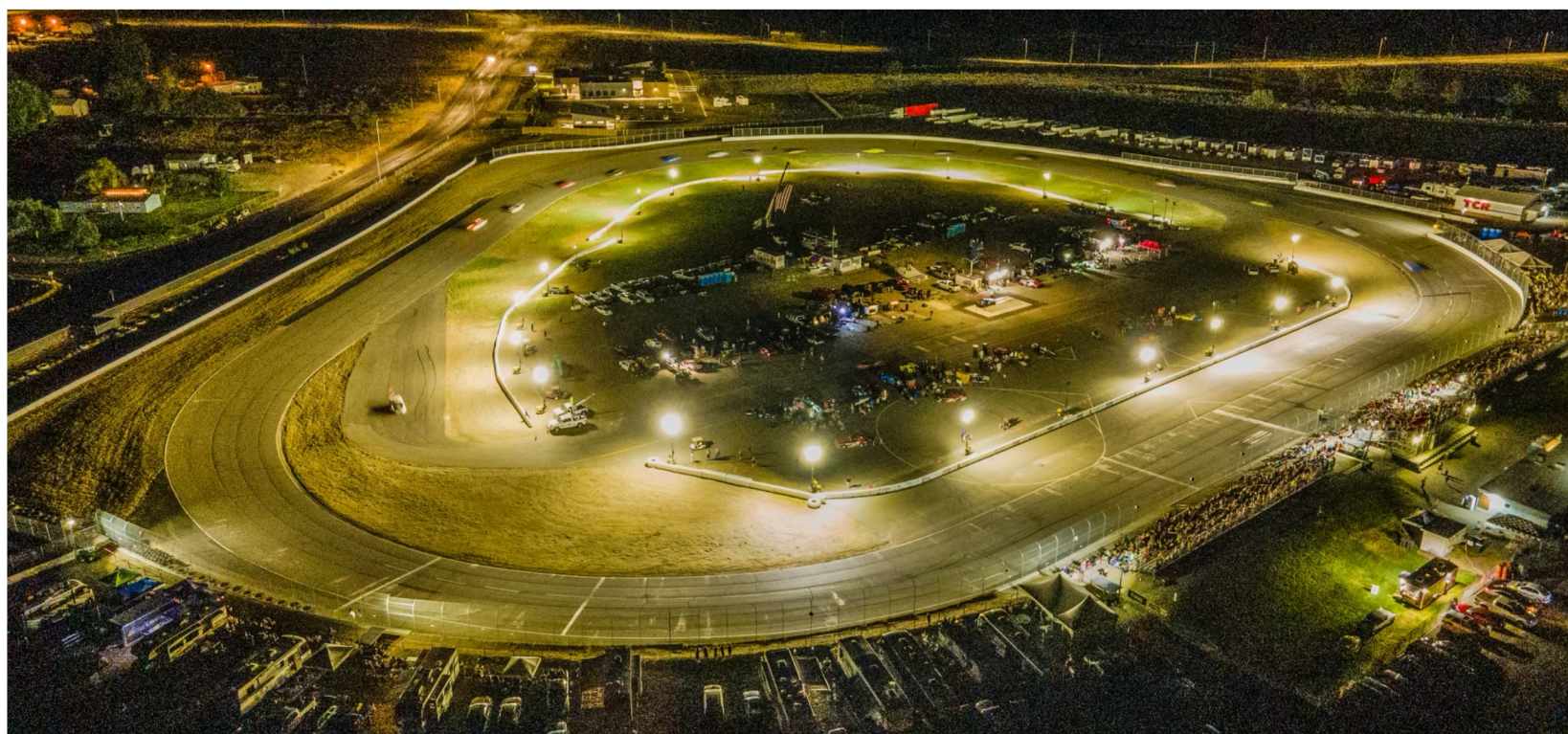



LARGEST SHORT TRACK RACING EVENTS ON THE WEST COAST!

TRI-CITY RACEWAY @ RMEC

TENTATIVE DATES

APRIL 3RD-6TH

56TH RUNNING APPLE CUP
(2 DAY STOCK CAR EVENT)

JULY

THUNDER @ THE MOUNTAIN
OR NIGHT OF THRILLS
(2 DAY SHOW)

AUGUST | TENTATIVE

NASCARS ARCA WEST SERIES
(2 DAY SHOW)

MAY OR SEPTEMBER TENTATIVE

NATIONAL ZMAX CARS TOUR
(2 DAY EVENT)

OCTOBER 2ND -5TH

38TH RUNNING FALL CLASSIC
(4 DAY EVENT - LARGEST WEST COAST STOCK CAR RACE)

OTHER EVENTS

SAND & SAGE SPORTS CAR CLUB

(AUTO CROSS) X 15

DTP WARS -TRUCK WARS,

MICHELADA CAR SHOW

HALLOWEEN TRUCK SHOW

CONCERTS

CORPORATE EVENTS

PRIVATE RENTALS

WA STATE CRIMINAL JUSTICE TRAINING COMMISSION





DEMOGRAPHICS + REPORTS PROJECTED GROWTH

Marketing overview:

We target heavily on a Regional Level targeting event enthusiast and tourist (Map generated from online ticket platform does not include competitors + teams)

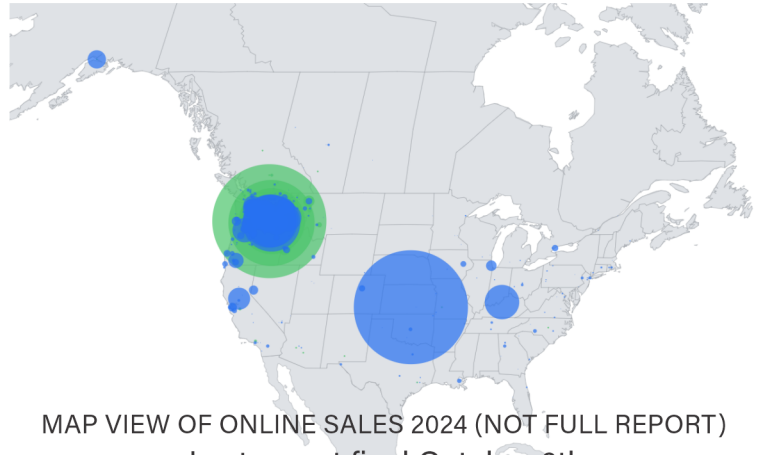

MAP VIEW OF ONLINE SALES 2024 (NOT FULL REPORT)
Last report final October 6th

Economic Growth of Facility (2020-2025)

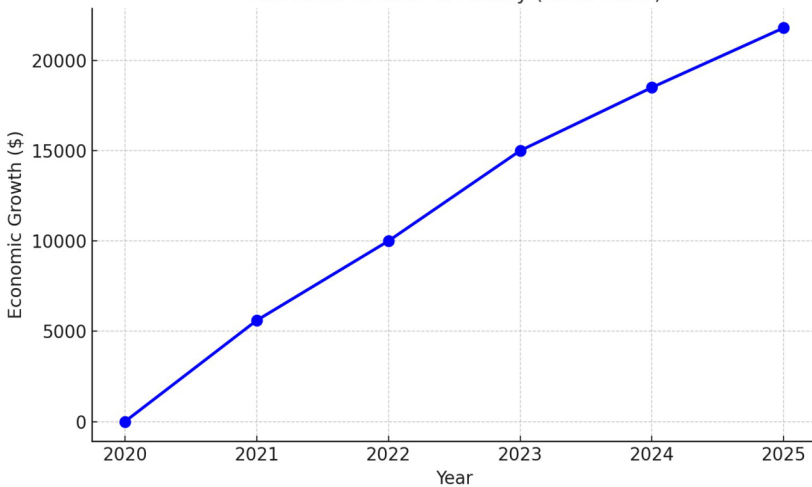

Stock Car Racing Events Only (growth)

Attendee growth pattern 5 year plan for National Stock Car Racing Venue. The chart shows a steady increase in the number of people attending Tri-City Raceway events from 2020 to 2025.

Attendance grows consistently over the years, indicating successful efforts in attracting more visitors.

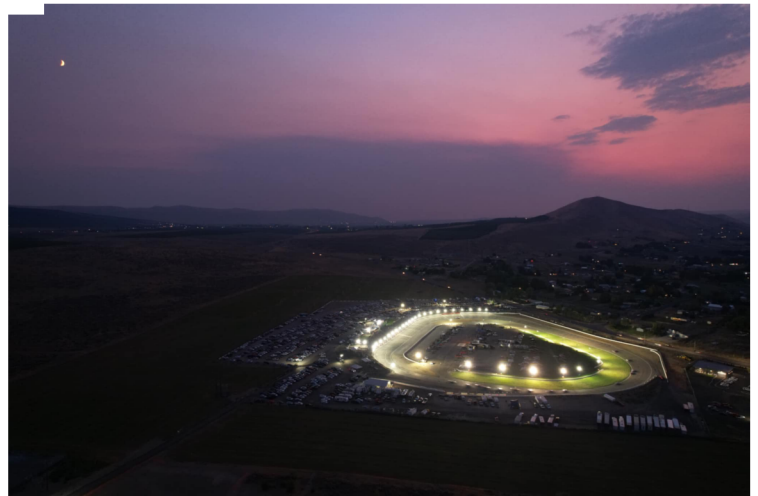



LODGING TAX ADVISORY COMMITTEE AGENDA ITEM ITEM COVERSHEET

Meeting Date: 10/14/2024

Agenda Category: Hotel/Motel Grant Applications

Prepared By: Brandie Soden

Subject:

Allied Arts Association - Art in the Park Festival

Department:

City Manager

Recommended Motion:

Summary:

Art in the Park is a signature annual event hosted each July in Howard Amon Park. Allied Arts Association is seeking \$12,000 in funding to support the event, which operates on a budget of \$68,000.

Fiscal Impact:

Art in the Park Festival is requesting \$12,000.

Attachments:

- I. Allied Arts Association - Art in the Park Festival



2025 Lodging Tax Grant Application

Please review the [LTAC Program Information](#) prior to beginning the application process.

Preview the application questions before you begin. The application is a one-time process; you cannot pause, save, or restart once you begin.

APPLICANT INFORMATION

*1. Name of Organization

Art in the Park Festival

*2. Business or Agency Type

Non-Profit

*3. Attach Completed W-9 Form

W9 Allied Arts Association 2025.jpg

4. Non-Profit Agencies - Attach Proof

2024 Allied Arts Associations Non Profit Tax Status Report.pdf

*5. Applicant Name

Mrs Brandie Soden

6. Applicant Title or Organizational Role

Director

*7. Full Address

89 Lee BLVD
Richland Washington 99352

*8. Applicant Phone Number

(509) 492-8833

*9. Applicant Email Address

artintheparkfestival@outlook.com

GRANT DETAILS

*10. Dollar Amount of Grant Funding Requested

12,000.00

*11. Grant Use Type

Event

12. For events or projects on City-owned property, please provide the name of the City employee you have reviewed this application with.

Gail Everett

*13. Title of the Proposed Event or Project

Allied Art Associations Art in the Park Festival

*14. Event or Project Description (will be used in the contract language if granted)

We have worked tirelessly in 2024 to grow our art event into being an art festival that will provide a significant summer draw to the Tri-Cities region, and to be a jewel in the City of Richlands list of accomplishments. There is absolutely NO OTHER art festival that is this big, this well attended, this expertly advertised, coordinated, or run anywhere in Eastern Washington and Eastern Oregon or Idaho. Our goal in 2025 is to grow our festival foot print by 20%, while increasing our attendance b

Non-Grant Funding Sources and Amounts

15. Tourism Marketing - Name of Funding Source

We do not currently have a sponsor for Tourism Marketing

16. Tourism Marketing - Dollar Amount

SKIPPED

17. Event/Festival Marketing - Name of Funding Source

We do not currently have a sponsor for Event/Festival Marketing

18. Event/Festival Marketing - Dollar Amount

SKIPPED

19. Tourism Facility Operation - Name of Funding Source

We do not currently have a sponsor for Tourism Facility Operation

20. Tourism Facility Operation - Dollar Amount

SKIPPED

***21. TOTAL NON-GRANT FUNDING BUDGET - Dollar Amount**

68,000.00

Grant Funding Requested - Planned Amounts and Distribution

22. Event/Festival Marketing - Dollar Amount

5,250.00

23. Tourism Marketing - Dollar Amount

5,250.00

24. Tourism Facility Operation - Dollar Amount

1,500.00

***25. TOTAL OF GRANT FUNDS - Dollar Amount**

12,000.00

ATTENDANCE ESTIMATES

The State of Washington **requires** attendance estimates, here are the accepted methods of calculation:

Direct Count: Actual count of visitors using methods such as paid admissions or registrations, clicker counts at entry points, vehicle counts or number of chairs filled. A direct count may also include information collected directly from businesses, such as hotels, restaurants or tour guides, likely to be affected by an event.

Indirect Count: Estimate based on information related to the number of visitors such as raffle tickets sold, redeemed discount certificates, brochures handed out, police requirements for crowd control or visual estimates.

Representative Survey: Information collected directly from individual visitors/participants. A representative survey is a highly structured data collection tool, based on a defined random sample of participants, and the results can be reliably projected to the entire population attending an event and includes margin of error and confidence level.

Informal Survey: Information collected directly from individual visitors or participants in a non-random manner that is not representative of all visitors or participants. Informal survey results cannot be projected to the entire visitor population and provide a limited indicator of attendance because not all participants had an equal chance of being included in the survey.

Structured Estimate: Estimate produced by computing known information related to the event or location. For example, one jurisdiction estimated attendance by dividing the square footage of the event area by the international building code allowance for persons (3 square feet).

***26. Predicted Overall Attendance - Estimation Method Used**

Indirect Count

***27. Predicted Overall Attendance - Estimated Number**

70,000

***28. Predicted Attendance, 50+ Miles - Estimation Method Used**

Indirect Count

***29. Predicted Attendance, 50+ Miles - Estimated Number**

3,000

***30. Predicted Attendance, Out of State, Out of Country - Estimation Method Used**

Direct Count

***31. Predicted Attendance, Out of State, Out of Country - Estimated Number**

13,000

***32. Predicted Attendance, Paid for Overnight Lodging - Estimation Method Used**

Direct Count

***33. Predicted Attendance, Paid for Overnight Lodging - Estimated Number**

9,000

***34. Predicted Attendance, Did Not Pay for Overnight Lodging - Estimation Method Used**

Indirect Count

***35. Predicted Attendance, Did Not Pay for Overnight Lodging - Estimated Number**

4,000

36. Predicted Paid Lodging Nights - Estimation Method Used

Direct Count

***37. Predicted Paid Lodging Nights - Estimated Number**

3

CONDITIONS FOR GRANT APPROVAL

38. Supplemental #1
SKIPPED

39. Supplement #2
SKIPPED

I acknowledge and agree to the below grant funding criteria:

1. I may be required to make a presentation to the advisory committee about my event/project.
2. All advertising will include the (provided) City of Richland logo and/or the phrase "Funding provided by City of Richland Lodging Tax Grant program."
3. I agree to submit marketing materials for approval by the Communications & Marketing Manager (or their designee) prior to publishing.
4. A final project report, including reporting requirements meeting state guidelines outlined in the LTAC Program Information document, and all supporting documents will be submitted to the City of Richland within 90 days of completion of the event or project AND must be expended within the calendar year in which they are granted.
5. I understand that grant progress will be monitored for compliance with scope and timeline.
6. If my event or project is on City-owned property, I have discussed this project with City staff and provided their name above.

***40. By typing my full name below, I agree to the above grant funding requirements, that I am authorized by my agency to submit this application and that all information provided herein is true and correct.**

Brandie Soden

City of Richland - 625 Swift Blvd, MS 39 - Richland, WA 99352
www.ci.richland.wa.us/LodgingTax

ALWAYS FREE

ALWAYS FUN



ART, MUSIC FOOD & YOU!

HILLSTOMP

**BON BON VIVANT - BOURBON & BELLOWS - LONESOME
JOHN & THE DOWNWIND DRIFTERS - BRAM BRATA, & MORE!**

STARTS AT

8AM

UNTIL 6PM

FRIDAY & SATURDAY

26-27

JULY

THE "STAGE"
PRESENTED BY



Featuring Robles Metal Art



2024 FESTIVAL INFO





LODGING TAX ADVISORY COMMITTEE AGENDA ITEM ITEM COVERSHEET

Meeting Date: 10/14/2024

Agenda Category: Hotel/Motel Grant Applications

Prepared By: Charlie Grigg

Subject:

Northwest Power Boat Association - Richland Regatta

Department:

City Manager

Recommended Motion:

Summary:

The Richland Regatta is an American Power Boat Association (APBA) boat race event held at Howard Amon Park, since 2016. The Northwest Powerboard Association is requesting \$17,500 with a non-grant funding budget of \$50,000.

Fiscal Impact:

The Northwest Powerboat Association is requesting \$17,500.

Attachments:

- I. 24-003 Northwest Power Boat Assoc. - Richland Regatta Event



2025 Lodging Tax Grant Application

Please review the [LTAC Program Information](#) prior to beginning the application process.

Preview the [application questions before you begin.](#) The application is a one-time process; you cannot pause, save, or restart once you begin.

APPLICANT INFORMATION

***1. Name of Organization**
Northwest Powerboat Association

*2. Business or Agency Type
Non-Profit

*3. Attach Completed W-9 Form
NWPBA W-9.pdf

4. Non-Profit Agencies - Attach Proof
NWPBA proof on Non-Profit.pdf

*5. Applicant Name
Charlie Grigg

6. Applicant Title or Organizational Role
President

*7. Full Address
PO Box 2222
Pasco WA 99301

*8. Applicant Phone Number
(509) 539-0050

*9. Applicant Email Address
charlie@griggsonline.com

GRANT DETAILS

***10. Dollar Amount of Grant Funding Requested**
17,500.00

*11. Grant Use Type
Event: on City-owned Property or Facility

12. For events or projects on City-owned property, please provide the name of the City employee you have reviewed this application with.
Stan Johnson, Gail Everette

*13. Title of the Proposed Event or Project
Richland Regatta

*14. Event or Project Description (will be used in the contract language if granted)
Richland Regatta is an APBA boat race held at Howard Amon Park, since 2016

Non-Grant Funding Sources and Amounts

15. Tourism Marketing - Name of Funding Source
SKIPPED

16. Tourism Marketing - Dollar Amount

SKIPPED

17. Event/Festival Marketing - Name of Funding Source

SKIPPED

18. Event/Festival Marketing - Dollar Amount

50,000.00

19. Tourism Facility Operation - Name of Funding Source

SKIPPED

20. Tourism Facility Operation - Dollar Amount

SKIPPED

***21. TOTAL NON-GRANT FUNDING BUDGET - Dollar Amount**

50,000.00

Grant Funding Requested - Planned Amounts and Distribution

22. Event/Festival Marketing - Dollar Amount

SKIPPED

23. Tourism Marketing - Dollar Amount

17,500.00

24. Tourism Facility Operation - Dollar Amount

SKIPPED

***25. TOTAL OF GRANT FUNDS - Dollar Amount**

17,500.00

ATTENDANCE ESTIMATES

The State of Washington **requires** attendance estimates, here are the accepted methods of calculation:

Direct Count: Actual count of visitors using methods such as paid admissions or registrations, clicker counts at entry points, vehicle counts or number of chairs filled. A direct count may also include information collected directly from businesses, such as hotels, restaurants or tour guides, likely to be affected by an event.

Indirect Count: Estimate based on information related to the number of visitors such as raffle tickets sold, redeemed discount certificates, brochures handed out, police requirements for crowd control or visual estimates.

Representative Survey: Information collected directly from individual visitors/participants. A representative survey is a highly structured data collection tool, based on a defined random sample of participants, and the results can be reliably projected to the entire population attending an event and includes margin of error and confidence level.

Informal Survey: Information collected directly from individual visitors or participants in a non-random manner that is not representative of all visitors or participants. Informal survey results cannot be projected to the entire visitor population and provide a limited indicator of attendance because not all participants had an equal chance of being included in the survey.

Structured Estimate: Estimate produced by computing known information related to the event or location. For example, one jurisdiction estimated attendance by dividing the square footage of the event area by the international building code allowance for persons (3 square feet).

***26. Predicted Overall Attendance - Estimation Method Used**

Informal Survey

***27. Predicted Overall Attendance - Estimated Number**

10,000

***28. Predicted Attendance, 50+ Miles - Estimation Method Used**

Informal Survey

***29. Predicted Attendance, 50+ Miles - Estimated Number**

750

***30. Predicted Attendance, Out of State, Out of Country - Estimation Method Used**

Informal Survey

***31. Predicted Attendance, Out of State, Out of Country - Estimated Number**

50

***32. Predicted Attendance, Paid for Overnight Lodging - Estimation Method Used**

Informal Survey

***33. Predicted Attendance, Paid for Overnight Lodging - Estimated Number**

280

***34. Predicted Attendance, Did Not Pay for Overnight Lodging - Estimation Method Used**

Informal Survey

***35. Predicted Attendance, Did Not Pay for Overnight Lodging - Estimated Number**

200

36. Predicted Paid Lodging Nights - Estimation Method Used

Informal Survey

***37. Predicted Paid Lodging Nights - Estimated Number**

10

CONDITIONS FOR GRANT APPROVAL

38. Supplemental #1
Hotel Motel Application Richland Regatta 2024.pdf

39. Supplement #2
024_HotelMotel_Tax_Funding - Signed copy.pdf

I acknowledge and agree to the below grant funding criteria:

1. I may be required to make a presentation to the advisory committee about my event/project.
2. All advertising will include the (provided) City of Richland logo and/or the phrase "Funding provided by City of Richland Lodging Tax Grant program."
3. I agree to submit marketing materials for approval by the Communications & Marketing Manager (or their designee) prior to publishing.
4. A final project report, including reporting requirements meeting state guidelines outlined in the LTAC Program Information document, and all supporting documents will be submitted to the City of Richland within 90 days of completion of the event or project AND must be expended within the calendar year in which they are granted.
5. I understand that grant progress will be monitored for compliance with scope and timeline.
6. If my event or project is on City-owned property, I have discussed this project with City staff and provided their name above.

***40. By typing my full name below, I agree to the above grant funding requirements, that I am authorized by my agency to submit this application and that all information provided herein is true and correct.**

Charlie Grigg

City of Richland - 625 Swift Blvd, MS 39 - Richland, WA 99352
www.ci.richland.wa.us/LodgingTax



LODGING TAX ADVISORY COMMITTEE AGENDA ITEM ITEM COVERSHEET

Meeting Date: 10/14/2024

Agenda Category: Hotel/Motel Grant Applications

Prepared By: Jennifer Little

Subject:
Stephens Media Group - Live@5

Department:
City Manager

Recommended Motion:

Summary:
Live@5 is a once-a-week live concert that runs for 11 weeks during the summer at the HAPO Community Stage. Stephens Media Group is requesting \$5,000 and have listed a non-grant funding budget of \$170,000.

Fiscal Impact:
Stephens Media Group is requesting \$5,000.

Attachments:
I. Stephens Media Group - Live@5



2025 Lodging Tax Grant Application

Please review the [LTAC Program Information](#) prior to beginning the application process.

Preview the [application questions before you begin](#). The application is a one-time process; you cannot pause, save, or restart once you begin.

APPLICANT INFORMATION

***1. Name of Organization**

Stephens Media Group

***2. Business or Agency Type**

For-Profit

***3. Attach Completed W-9 Form**

SMG w9.pdf

4. Non-Profit Agencies - Attach Proof

SKIPPED

***5. Applicant Name**

Events & Promotions Manager Jennifer Little

6. Applicant Title or Organizational Role

Events & Promotions Manager

***7. Full Address**

4304 W 24th Ave Suite 200
Kennewick WA 99338

***8. Applicant Phone Number**

(253) 670-3522

***9. Applicant Email Address**

jennifer.little@smgnational.com

GRANT DETAILS

***10. Dollar Amount of Grant Funding Requested**

5,000.00

***11. Grant Use Type**

Event

12. For events or projects on City-owned property, please provide the name of the City employee you have reviewed this application with.

Sherry Gartside

***13. Title of the Proposed Event or Project**

Live@5

***14. Event or Project Description (will be used in the contract language if granted)**

21st Annual Live@5 Summer Concert Series. Free to the public and family friendly, Live@5 is a once a week (Thursdays) live concert that runs for 11 weeks during the summer. Food vendors, local businesses, kid zone and beer garden.

Non-Grant Funding Sources and Amounts

15. Tourism Marketing - Name of Funding Source

Stephens Media Group-Radio, print, social media

16. Tourism Marketing - Dollar Amount

50,000.00

17. Event/Festival Marketing - Name of Funding Source

Stephens Media Group- radio, print, social media

18. Event/Festival Marketing - Dollar Amount

120,000.00

19. Tourism Facility Operation - Name of Funding Source

na

20. Tourism Facility Operation - Dollar Amount

SKIPPED

***21. TOTAL NON-GRANT FUNDING BUDGET - Dollar Amount**

170,000.00

Grant Funding Requested - Planned Amounts and Distribution

22. Event/Festival Marketing - Dollar Amount

10,000.00

23. Tourism Marketing - Dollar Amount

5,000.00

24. Tourism Facility Operation - Dollar Amount

SKIPPED

***25. TOTAL OF GRANT FUNDS - Dollar Amount**

15,000.00

ATTENDANCE ESTIMATES

The State of Washington **requires** attendance estimates, here are the accepted methods of calculation:

Direct Count: Actual count of visitors using methods such as paid admissions or registrations, clicker counts at entry points, vehicle counts or number of chairs filled. A direct count may also include information collected directly from businesses, such as hotels, restaurants or tour guides, likely to be affected by an event.

Indirect Count: Estimate based on information related to the number of visitors such as raffle tickets sold, redeemed discount certificates, brochures handed out, police requirements for crowd control or visual estimates.

Representative Survey: Information collected directly from individual visitors/participants. A representative survey is a highly structured data collection tool, based on a defined random sample of participants, and the results can be reliably projected to the entire population attending an event and includes margin of error and confidence level.

Informal Survey: Information collected directly from individual visitors or participants in a non-random manner that is not representative of all visitors or participants. Informal survey results cannot be projected to the entire visitor population and provide a limited indicator of attendance because not all participants had an equal chance of being included in the survey.

Structured Estimate: Estimate produced by computing known information related to the event or location. For example, one jurisdiction estimated attendance by dividing the square footage of the event area by the international building code allowance for persons (3 square feet).

***26. Predicted Overall Attendance - Estimation Method Used**

Structured Estimate

***27. Predicted Overall Attendance - Estimated Number**

27,500

***28. Predicted Attendance, 50+ Miles - Estimation Method Used**

Indirect Count

***29. Predicted Attendance, 50+ Miles - Estimated Number**

250

***30. Predicted Attendance, Out of State, Out of Country - Estimation Method Used**

Indirect Count

***31. Predicted Attendance, Out of State, Out of Country - Estimated Number**

250

***32. Predicted Attendance, Paid for Overnight Lodging - Estimation Method Used**

Structured Estimate

***33. Predicted Attendance, Paid for Overnight Lodging - Estimated Number**

125

***34. Predicted Attendance, Did Not Pay for Overnight Lodging - Estimation Method Used**

Indirect Count

***35. Predicted Attendance, Did Not Pay for Overnight Lodging - Estimated Number**

125

36. Predicted Paid Lodging Nights - Estimation Method Used

Indirect Count

***37. Predicted Paid Lodging Nights - Estimated Number**

6

CONDITIONS FOR GRANT APPROVAL

38. Supplemental #1
Live@5.jpg

39. Supplement #2
SKIPPED

I acknowledge and agree to the below grant funding criteria:

1. I may be required to make a presentation to the advisory committee about my event/project.
2. All advertising will include the (provided) City of Richland logo and/or the phrase "Funding provided by City of Richland Lodging Tax Grant program."
3. I agree to submit marketing materials for approval by the Communications & Marketing Manager (or their designee) prior to publishing.
4. A final project report, including reporting requirements meeting state guidelines outlined in the LTAC Program Information document, and all supporting documents will be submitted to the City of Richland within 90 days of completion of the event or project AND must be expended within the calendar year in which they are granted.
5. I understand that grant progress will be monitored for compliance with scope and timeline.
6. If my event or project is on City-owned property, I have discussed this project with City staff and provided their name above.

***40. By typing my full name below, I agree to the above grant funding requirements, that I am authorized by my agency to submit this application and that all information provided herein is true and correct.**

Jennifer Little

City of Richland - 625 Swift Blvd, MS 39 - Richland, WA 99352
www.ci.richland.wa.us/LodgingTax

Anniv

Community Credit Union

LIVE @ 5

SUMMER CONCERT FESTIVAL

MAY 23 - DR. ROCK & THE STURGEONS

MAY 30 - BACK ROADS

JUNE 6 - THE KNOCKDOWNS

JUNE 13 - GROOVE PRINCIPAL

JUNE 20 - RED LIGHT CHALLENGE

JUNE 27 - QUEEN'S GATE

JULY 4 - **NO LIVE @ 5**

JULY 11 - ENGLEWOOD HEIGHTS

JULY 18 - AMERICAN HONEY

JULY 25 - JOEL GIBSON JR.

AUGUST 1 - JAGERNAUTS

AUGUST 8 - UOO DOO ALLEY

JOHN DAM PLAZA / RICHLAND, WA



Summer Concert Series

**MORE THAN 5,000
PROMOTIONAL
ANNOUNCEMENTS**

All 6 Radio
Stations
advertising
Live@5

Every year this
event attracts
thousands of
people from
right here in the
Tri Cities and
out of state

Attendees range
demographically
from families
with young
children to our
seniors with





LODGING TAX ADVISORY COMMITTEE AGENDA ITEM ITEM COVERSHEET

Meeting Date: 10/14/2024

Agenda Category: Hotel/Motel Grant Applications

Prepared By: Katrina Knight

Subject:

Three Rivers Folklife Society - Tumbleweed Music Festival

Department:

City Manager

Recommended Motion:

Summary:

The Tumbleweed Music Festival is an annual 3-day event held over Labor Day weekend in Howard Amon Park with an added virtual component. Three Rivers Folklife Society is requesting \$7,000 in grant funding and has an operating budget of over \$53,000.

Fiscal Impact:

Three Rivers Folklife Society is requesting \$7,000.

Attachments:

- I. Three Rivers Folklife Society - Tumbleweed Music Festival



2025 Lodging Tax Grant Application

Please review the [LTAC Program Information](#) prior to beginning the application process.

Preview the application questions before you begin. The application is a one-time process; you cannot pause, save, or restart once you begin.

APPLICANT INFORMATION

***1. Name of Organization**
Three Rivers Folklife Society

*2. Business or Agency Type
Non-Profit

*3. Attach Completed W-9 Form
Form W-9.pdf

4. Non-Profit Agencies - Attach Proof
2011-07-11_determination-combined.pdf

*5. Applicant Name
Katrina Knight

6. Applicant Title or Organizational Role
Tumbleweed Music Festival Coordinator

*7. Full Address
PO Box 1098
Richland Washington 99352

*8. Applicant Phone Number
(610) 406-2500

*9. Applicant Email Address
tumbleweedchair@gmail.com

GRANT DETAILS

***10. Dollar Amount of Grant Funding Requested**
7,000.00

*11. Grant Use Type
Event: on City-owned Property or Facility

12. For events or projects on City-owned property, please provide the name of the City employee you have reviewed this application with.
we work with Stan Johnson at Howard Amon Park

***13. Title of the Proposed Event or Project**
Tumbleweed Music Festival

***14. Event or Project Description (will be used in the contract language if granted)**
The Tumbleweed Music Festival is an annual 3-day event held over Labor Day weekend in Howard Amon Park with an added virtual component. It features a variety of acoustic music, dance, and folk arts. Workshops, jams, and sing-alongs provide opportunities for audience participation. There are crafts booths and food vendors. Most performers are from the Northwest but some come from around the country and the world. In 2024 one came all the way from Viet Nam.

Non-Grant Funding Sources and Amounts

15. Tourism Marketing - Name of Funding Source
n/a

16. Tourism Marketing - Dollar Amount

SKIPPED

17. Event/Festival Marketing - Name of Funding Source

our own funds

18. Event/Festival Marketing - Dollar Amount

4,000.00

19. Tourism Facility Operation - Name of Funding Source

n/a

20. Tourism Facility Operation - Dollar Amount

SKIPPED

***21. TOTAL NON-GRANT FUNDING BUDGET - Dollar Amount**

4,000.00

Grant Funding Requested - Planned Amounts and Distribution

22. Event/Festival Marketing - Dollar Amount

7,000.00

23. Tourism Marketing - Dollar Amount

SKIPPED

24. Tourism Facility Operation - Dollar Amount

SKIPPED

***25. TOTAL OF GRANT FUNDS - Dollar Amount**

7,000.00

ATTENDANCE ESTIMATES

The State of Washington **requires** attendance estimates, here are the accepted methods of calculation:

Direct Count: Actual count of visitors using methods such as paid admissions or registrations, clicker counts at entry points, vehicle counts or number of chairs filled. A direct count may also include information collected directly from businesses, such as hotels, restaurants or tour guides, likely to be affected by an event.

Indirect Count: Estimate based on information related to the number of visitors such as raffle tickets sold, redeemed discount certificates, brochures handed out, police requirements for crowd control or visual estimates.

Representative Survey: Information collected directly from individual visitors/participants. A representative survey is a highly structured data collection tool, based on a defined random sample of participants, and the results can be reliably projected to the entire population attending an event and includes margin of error and confidence level.

Informal Survey: Information collected directly from individual visitors or participants in a non-random manner that is not representative of all visitors or participants. Informal survey results cannot be projected to the entire visitor population and provide a limited indicator of attendance because not all participants had an equal chance of being included in the survey.

Structured Estimate: Estimate produced by computing known information related to the event or location. For example, one jurisdiction estimated attendance by dividing the square footage of the event area by the international building code allowance for persons (3 square feet).

***26. Predicted Overall Attendance - Estimation Method Used**

Structured Estimate

***27. Predicted Overall Attendance - Estimated Number**

4,000

***28. Predicted Attendance, 50+ Miles - Estimation Method Used**

Informal Survey

***29. Predicted Attendance, 50+ Miles - Estimated Number**

1,200

***30. Predicted Attendance, Out of State, Out of Country - Estimation Method Used**

Informal Survey

***31. Predicted Attendance, Out of State, Out of Country - Estimated Number**

300

***32. Predicted Attendance, Paid for Overnight Lodging - Estimation Method Used**

Informal Survey

***33. Predicted Attendance, Paid for Overnight Lodging - Estimated Number**

600

***34. Predicted Attendance, Did Not Pay for Overnight Lodging - Estimation Method Used**

Informal Survey

***35. Predicted Attendance, Did Not Pay for Overnight Lodging - Estimated Number**

3,400

36. Predicted Paid Lodging Nights - Estimation Method Used

Informal Survey

***37. Predicted Paid Lodging Nights - Estimated Number**

900

CONDITIONS FOR GRANT APPROVAL

38. Supplemental #1
TMF2024 Poster - design 3 final.pdf

39. Supplement #2
Spokane ad.pdf

I acknowledge and agree to the below grant funding criteria:

1. I may be required to make a presentation to the advisory committee about my event/project.
2. All advertising will include the (provided) City of Richland logo and/or the phrase "Funding provided by City of Richland Lodging Tax Grant program."
3. I agree to submit marketing materials for approval by the Communications & Marketing Manager (or their designee) prior to publishing.
4. A final project report, including reporting requirements meeting state guidelines outlined in the LTAC Program Information document, and all supporting documents will be submitted to the City of Richland within 90 days of completion of the event or project AND must be expended within the calendar year in which they are granted.
5. I understand that grant progress will be monitored for compliance with scope and timeline.
6. If my event or project is on City-owned property, I have discussed this project with City staff and provided their name above.

***40. By typing my full name below, I agree to the above grant funding requirements, that I am authorized by my agency to submit this application and that all information provided herein is true and correct.**

Katrina Knight

City of Richland - 625 Swift Blvd, MS 39 - Richland, WA 99352
www.ci.richland.wa.us/LodgingTax

Tumbleweed Music Festival

Great Acoustic Music Along the Columbia River

Labor Day Weekend

August 30 – September 1

Howard Amon Park, Richland, WA



FREE! *

* Except Saturday Concert
& Sunday Dance

100 Plus Acts on 5 stages!

Workshops!
Open Mic Stage!

Food and Craft Vendors!

WWW.TUMBLEWEEDFEST.COM

WWW.TUMBLEWEEDMUSICFESTIVAL.ORG





LABOR DAY WEEKEND AUGUST 30 - SEPTEMBER 1

Great Acoustic Music Along the Columbia River

Howard Amon Park, Richland, WA



FREE! *

Food and Craft Vendors!

100 Plus Acts!

Workshops!

* Except Saturday Concert
& Sunday Dance

Six Stages plus Dance Floor!

Open Mic Stage!

WWW.TUMBLEWEEDFEST.COM

WWW.TUMBLEWEEDMUSICFESTIVAL.ORG

Our Saturday Concert Headliners:

HOMEBREW STRINGBAND

MIKE AND CARLEEN MCCORNACK

WILLIAM PINT & FELICIA DALE



tweedmusicfest.bsky.social



[@TweedMusicFest](https://www.instagram.com/TweedMusicFest)



[@TweedMusicFest](https://www.tiktok.com/@TweedMusicFest)



[@TweedMusicFest](https://twitter.com/TweedMusicFest)



[@tumbleweedfest](https://www.facebook.com/tumbleweedfest)



tumbleweedfest.com



**NORTHWEST
PUBLIC BROADCASTING**



**PASCO
Chamber of Commu**

TUMBLEWEIRD

POSITIVELY WEIRD. NEVER TIMID.

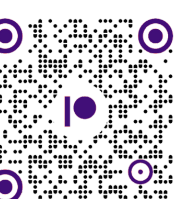



LODGING TAX ADVISORY COMMITTEE AGENDA ITEM ITEM COVERSHEET

Meeting Date: 10/14/2024

Agenda Category: Hotel/Motel Grant Applications

Prepared By: Terry Marie Fleischman

Subject:

Tri-Cities Sunrise Rotary - See3Slam 2025 - 3 on 3 Basketball Tournament

Department:

City Manager

Recommended Motion:

Summary:

Tri-Cities Sunrise Rotary hosts See3slam 2025 on George Washington Way at John Dam Plaza. The event includes a 3-on-3 basketball tournament for all ages. TC Sunrise Rotary is requesting \$10,000 and has an operating budget of approximately \$75,000.

Fiscal Impact:

Tri-Cities Sunrise Rotary is requesting \$10,000.

Attachments:

- I. Tri-Cities Sunrise Rotary - See3Slam 2025 - 3 on 3 Basketball Tournament

Submission # 3496160
IP Address 47.25.178.2
Submission Recorded On 09/19/2024 3:19 PM
Time to Take Survey 41 minutes, 15 seconds



Please review the [LTAC Program Information](#) prior to beginning the application process.

Preview the application questions before you begin. The application is a one-time process; you cannot pause, save, or restart once you begin.

APPLICANT INFORMATION

- * **1. Name of Organization** ?
Tri Cities Sunrise Rotary Club Charity
- * **2. Business or Agency Type**
Non-Profit
- * **3. Attach Completed W-9 Form** ?
Charity W-9_2024.pdf
- * **4. Non-Profit Agencies - Attach Proof** ?
TCSunriseRotary_CharityStatus_EIN_pg1.pdf
- * **5. Applicant Name** ?
Ms. Terry Marie Fleischman
- * **6. Applicant Title or Organizational Role**
TC Sunrise Rotary Public Relations Chair / See3Slam Event Director
- * **7. Full Address**
1321 Hains Avenue
Richland Washington 99354
- * **8. Applicant Phone Number** ?
(509) 947-1106
- * **9. Applicant Email Address** ?
terry@see3slam.com

GRANT DETAILS

- * **10. Dollar Amount of Grant Funding Requested** ?
10,000.00
- * **11. Grant Use Type** ?
Event: on City-owned Property or Facility
- * **12. For events or projects on City-owned property, please provide the name of the City employee you have reviewed this application with.** ?
Sherry Gartside /Stan Johnson/ Shawn Harper
- * **13. Title of the Proposed Event or Project** ?
See3Slam2025: 3-on-3 Basketball Tournament
- * **14. Event or Project Description (will be used in the contract language if granted)** ?
TC Sunrise Rotary partners with the City of Richland to present See3slam 2025 on George Washington Way at John Dam Plaza. The event includes a 3-on-3 basketball tournament for ALL ages, food, entertainment, exhibition games, clinics and center court contests including shoot outs for adults to win cash and youth to win outdoor recreational equipment - all contributed by premier sponsors. Visit www.see3slam.com

Non-Grant Funding Sources and Amounts

- * **15. Tourism Marketing - Name of Funding Source** ?
N/A
- * **16. Tourism Marketing - Dollar Amount** ?
SKIPPED
- * **17. Event/Festival Marketing - Name of Funding Source** ?
Sponsorships, Registrations Fees, Vendor fees, product sales

18. Event/Festival Marketing - Dollar Amount ?

25,000.00

19. Tourism Facility Operation - Name of Funding Source ?

N/A

20. Tourism Facility Operation - Dollar Amount ?

SKIPPED

*** 21. TOTAL NON-GRANT FUNDING BUDGET - Dollar Amount** ?

25,000.00

Grant Funding Requested - Planned Amounts and Distribution

22. Event/Festival Marketing - Dollar Amount ?

10,000.00

23. Tourism Marketing - Dollar Amount ?

SKIPPED

24. Tourism Facility Operation - Dollar Amount ?

SKIPPED

*** 25. TOTAL OF GRANT FUNDS - Dollar Amount** ?

10,000.00

Page 3 - Attendance Estimates

ATTENDANCE ESTIMATES

The State of Washington **requires** attendance estimates, here are the accepted methods of calculation:

Direct Count: Actual count of visitors using methods such as paid admissions or registrations, clicker counts at entry points, vehicle counts or number of chairs filled. A direct count may also include information collected directly from businesses, such as hotels, restaurants or tour guides, likely to be affected by an event.

Indirect Count: Estimate based on information related to the number of visitors such as raffle tickets sold, redeemed discount certificates, brochures handed out, police requirements for crowd control or visual estimates.

Representative Survey: Information collected directly from individual visitors/participants. A representative survey is a highly structured data collection tool, based on a defined random sample of participants, and the results can be reliably projected to the entire population attending an event and includes margin of error and confidence level.

Informal Survey: Information collected directly from individual visitors or participants in a non-random manner that is not representative of all visitors or participants. Informal survey results cannot be projected to the entire visitor population and provide a limited indicator of attendance because not all participants had an equal chance of being included in the survey.

Structured Estimate: Estimate produced by computing known information related to the event or location. For example, one jurisdiction estimated attendance by dividing the square footage of the event area by the international building code allowance for persons (3 square feet).

*** 26. Predicted Overall Attendance - Estimation Method Used** ?

Direct Count

*** 27. Predicted Overall Attendance - Estimated Number** ?

3,500

*** 28. Predicted Attendance, 50+ Miles - Estimation Method Used** ?

Direct Count

*** 29. Predicted Attendance, 50+ Miles - Estimated Number** ?

750

*** 30. Predicted Attendance, Out of State, Out of Country - Estimation Method Used** ?

Direct Count

*** 31. Predicted Attendance, Out of State, Out of Country - Estimated Number** ?

300

*** 32. Predicted Attendance, Paid for Overnight Lodging - Estimation Method Used** ?

Direct Count

*** 33. Predicted Attendance, Paid for Overnight Lodging - Estimated Number** ?

300

*** 34. Predicted Attendance, Did Not Pay for Overnight Lodging - Estimation Method Used** ?

Direct Count

*** 35. Predicted Attendance, Did Not Pay for Overnight Lodging - Estimated Number** ?

3,200

36. Predicted Paid Lodging Nights - Estimation Method Used ?

Direct Count

*** 37. Predicted Paid Lodging Nights - Estimated Number** ?

400

Page 4 - Conditions for Grant Approval

CONDITIONS FOR GRANT APPROVAL

38. Supplemental #1 ?

HotelMotel_EventPromo.pdf

39. Supplement #2 ?

****SKIPPED****

I acknowledge and agree to the below grant funding criteria:

1. I may be required to make a presentation to the advisory committee about my event/project.
2. All advertising will include the (provided) City of Richland logo and/or the phrase "Funding provided by City of Richland Lodging Tax Grant program."
3. I agree to submit marketing materials for approval by the Communications & Marketing Manager (or their designee) prior to publishing.
4. A final project report, including reporting requirements meeting state guidelines outlined in the LTAC Program Information document, and all supporting documents will be submitted to the City of Richland within 90 days of completion of the event or project AND must be expended within the calendar year in which they are granted.
5. I understand that grant progress will be monitored for compliance with scope and timeline.
6. If my event or project is on City-owned property, I have discussed this project with City staff and provided their name above.

*

40. By typing my full name below, I agree to the above grant funding requirements, that I am authorized by my agency to submit this application and that all information provided herein is true and correct. ?

Terry Marie Fleischman

City of Richland - 625 Swift Blvd, MS 39 - Richland, WA 99352
www.ci.richland.wa.us/LodgingTax



**SAVE
THE
DATE!**

**JULY
13-14
2024**



SEE 3 SLAM
TOURNAMENT

Rotary
Tri-Cities Sunrise



TRI·CU
CREDIT UNION

A large graphic of an orange basketball with a blue and white hoop in the center, set against a yellow circular background.

SEE 3 SLAM

TOURNAMENT



SAVE THE DATE! JULY 13 - 14, 2024

Contests, Exhibitions, Vendors and more!
JOHN DAM PLAZA | RICHLAND, WA
See3Slam.com

TRI·CU
CREDIT UNION

Rotary 
Tri-Cities Sunrise



SEE3SLAM
TOURNAMENT
RICHLAND, WA

SEE3SLAM.COM

TRI·CU
CREDIT UNION

Rotary 
Tri-Cities Sunrise



SEE 3 SLAM
TOURNAMENT
RICHLAND, WA

2ND WEEKEND IN JULY

Rotary
Tri-Cities Sunrise



SPONSORED BY

TRI·CU
CREDIT UNION



SEE 3 SLAM

TOURNAMENT

JULY 13-14, 2024
JOHN DAM PLAZA RICHLAND, WA

KUSTOM
RESTORATION
PRESENTS

KOOL CASH SHOOTOUT!
WIN \$1000!

TRI·CU
CREDIT UNION

KIDS HOOPLA!

WIN A BIKE,
SCOOTER OR
SKATEBOARD

See3Slam.com

Funds raised support local charities and provide cataract surgeries in Africa!



PLAYERS (GRAY)



**SILVER, BLUE, ORANGE METALLIC INK
+BLACK INK**

CHAMPIONS (BLUE)



YOUTH PLAYERS (GRAY)



VOLUNTEER (SAFETY GREEN)



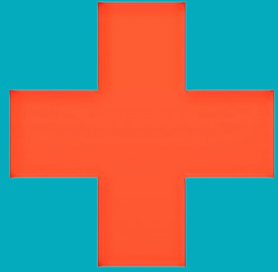

HEAT ADVISORY

SEE3SLAM 2024

TO BE ONE OF THE HOTTEST ON RECORD

- HYDRATE!** Drink water before, during and after the games – ideally every 15 minutes
- SEEK SHADE!** Visit the multiple Sunbelt Cool Zone Tents with misters and water fans on site
- GET COOL!** Grab a quick 5-minute cool down in a Broadmoor-RV air-conditioned unit on site
- SUNSCREEN!** Frequently layer on sunscreen for extra protection
- FIRST AID!** TCRS medic station has first aid supplies, hydration powder, ice, water & neck coolers

Due to the extreme heat, See3Slam organizers have taken extra precautions to restructure the game schedule to minimize continuous play and have included multiple 30-60 minute all-court game breaks.

Be sure to frequently monitor your bracket for change in game time or court assignment.

PLAYER HEALTH AND SAFETY IS OUR PRIORITY! PREVENTION IS KEY!



THANK YOU FOR YOUR SUPPORT TRI-CITIES!

SPONSORED BY

TRI·CU
CREDIT UNION

Rotary
Tri-Cities Sunrise



**JOHN DAM PLAZA
& GEORGE
WASHINGTON
WAY**





SEE3SLAM

TOURNAMENT

JULY 13-14, 2024 RICHLAND, WA

LIT Tri-Cities Sunrise Rotary TRI-CU CREDIT UNION Richland Abadan



LODGING TAX ADVISORY COMMITTEE AGENDA ITEM ITEM COVERSHEET

Meeting Date: 10/14/2024

Agenda Category: New Business

Prepared By: Hollie Alexander, Communications & Marketing Manager

Subject:
Grant Funding Recommendation to Council

Department:
City Manager

Recommended Motion:

Summary:
LTAC Members will discuss and vote on grant requests and forward their recommendations to City Council.

Fiscal Impact:

Attachments: